

PSIS 11-230V

EN

OPERATING MANUAL
SOLDERING STATION



 TROTEC

Table of contents

Notes regarding the operating manual..... 2

Safety 2

Information about the device..... 7

Transport and storage..... 8

Start-up..... 8

Operation 9

Available accessories..... 11

Errors and faults..... 11

Maintenance 12

Disposal 12

Notes regarding the operating manual

Symbols



Warning of electrical voltage

This symbol indicates dangers to the life and health of persons due to electrical voltage.



Warning of hot surface

This symbol indicates dangers to the life and health of persons due to hot surface.



Warning

This signal word indicates a hazard with an average risk level which, if not avoided, can result in serious injury or death.



Caution

This signal word indicates a hazard with a low risk level which, if not avoided, can result in minor or moderate injury.

Note

This signal word indicates important information (e.g. material damage), but does not indicate hazards.



Info

Information marked with this symbol helps you to carry out your tasks quickly and safely.



Follow the manual

Information marked with this symbol indicates that the operating manual must be observed.



Wear safety glasses

Information marked with this symbol indicates that you should wear eye protection.

You can download the current version of the operating manual and the EU declaration of conformity via the following link:

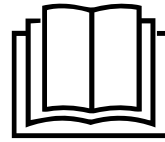

PSIS 11-230V



<https://hub.trotec.com/?id=45843>

Safety

General Power Tool Safety Warnings



Warning

Read all safety warnings, instructions, illustrations and specifications provided with this power tool.

Failure to follow all instructions listed below may result in electric shock, fire and/or serious injury.

Save all warnings and instructions for future reference.



Warning

Read all safety warnings and all instructions.

Failure to follow the warnings and instructions may result in electric shock, fire and/or serious injury.

Save all warnings and instructions for future reference.

This device must not be used by children and persons under 16 years of age.

Children shall not play with the appliance. Cleaning and user maintenance shall not be made by children under 16 years.

The term *power tool* in the warnings refers to your mains-operated (corded) power tool or battery-operated (cordless) power tool.

 **General Power Tool Safety Warnings – Work area safety**

- **Keep work area clean and well lit.** Clutter or dark areas invite accidents.
- **Do not operate power tools in explosive atmosphere, such as in the presence of flammable liquids, gases or dust.** Power tools create sparks which may ignite the dust or fumes.
- **Keep children and bystanders away while operating a power tool.** Distractions can cause you to lose control.

 **General Power Tool Safety Warnings – Electrical safety**

- **Power tool plugs must match the outlet. Never modify the plug in any way. Do not use any adapter plugs with earthed (grounded) power tools.** Unmodified plugs and matching outlets will reduce risk of electric shock.
- **Avoid body contact with earthed or grounded surfaces, such as pipes, radiators, ranges and refrigerators.** There is an increased risk of electric shock if your body is earthed or grounded.
- **Do not expose power tools to rain or wet conditions.** Water entering a power tool will increase the risk of electric shock.
- **Do not abuse the cord. Never use the cord for carrying, pulling or unplugging the power tool. Keep cord away from heat, oil, sharp edges or moving parts.** Damaged or entangled cords increase the risk of electric shock.
- **When operating a power tool outdoors, use an extension cord suitable for outdoor use.** Use of a cord suitable for outdoor use reduces the risk of electric shock.
- **If operating a power tool in a damp location is unavoidable, use a residual current device (RCD) protected supply.** Use of an RCD reduces the risk of electric shock.

 **General Power Tool Safety Warnings – Personal safety**

- **Stay alert, watch what you are doing and use common sense when operating a power tool. Do not use a power tool while you are tired or under the influence of drugs, alcohol or medication.** A moment of inattention while operating power tools may result in serious personal injury.
- **Use personal protective equipment. Always wear eye protection.** Protective equipment such as a dust mask, non-skid safety shoes, hard hat or hearing protection used for appropriate conditions will reduce personal injuries.
- **Prevent unintentional starting. Ensure the switch is in the off-position before connecting to power source and/or battery pack, picking up or carrying the tool.** Carrying power tools with your finger on the switch or energising power tools that have the switch on invites accidents.
- **Remove any adjusting key or wrench before turning the power tool on.** A wrench or a key left attached to a rotating part of the power tool may result in personal injury.
- **Do not overreach. Keep proper footing and balance at all times.** This enables better control of the power tool in unexpected situations.
- **Dress properly. Do not wear loose clothing or jewellery. Keep your hair and clothing away from moving parts.** Loose clothes, jewellery or long hair can be caught in moving parts.
- **If devices are provided for the connection of dust extraction and collection facilities, ensure these are connected and properly used.** Use of dust collection can reduce dust-related hazards.
- **Do not let familiarity gained from frequent use of tools allow you to become complacent and ignore tool safety principles.** A careless action can cause severe injury within a fraction of a second.

**General Power Tool Safety Warnings – Power tool use and care**

- **Do not force the power tool. Use the correct power tool for your application.** The correct power tool will do the job better and safer at the rate for which it was designed.
- **Do not use the power tool if the switch does not turn it on and off.** Any power tool that cannot be controlled with the switch is dangerous and must be repaired.
- **Disconnect the plug from the power source and/or remove the battery pack, if detachable, from the power tool before making any adjustments, changing accessories, or storing power tools.** Such preventive safety measures reduce the risk of starting the power tool accidentally.
- **Store idle power tools out of the reach of children and do not allow persons unfamiliar with the power tool or these instructions to operate the power tool.** Power tools are dangerous in the hands of untrained users.
- **Maintain power tools and accessories. Check for misalignment or binding of moving parts, breakage of parts and any other condition that may affect the power tool's operation. If damaged, have the power tool repaired before use.** Many accidents are caused by poorly maintained power tools.
- **Keep cutting tools sharp and clean.** Properly maintained cutting tools with sharp cutting edges are less likely to bind and are easier to control.
- **Use the power tool, accessories and tool bits etc. in accordance with these instructions, taking into account the working conditions and the work to be performed.** Use of the power tool for operations different from those intended could result in a hazardous situation.
- **Keep handles and grasping surfaces dry, clean and free from oil and grease.** Slippery handles and grasping surfaces do not allow for safe handling and control of the tool in unexpected situations.

**General Power Tool Safety Warnings – Service**

- **Have your power tool serviced by a qualified repair person using only identical replacement parts.** This will ensure that the safety of the power tool is maintained.

**Device-specific safety warnings for soldering stations**

- **Never touch the heated soldering tip or the molten solder.** Risk of burns.
- **Do not under any circumstances use water to cool down the soldering iron.** Only allow the soldering iron to cool down in the air after use.
- **Use the holder if you interrupt your work for breaks or for setting the soldering iron down.** The high temperature of the soldering iron can set inappropriate mats on fire.
- **Keep the device at a distance of combustible materials.**
- **Do not inhale vapours.** If you perform longer works during which vapours hazardous to health may occur, always provide sufficient ventilation of the workplace.
- **Avoid touching the hot soldering tip with the plastic parts of the holder.** Otherwise the device may be damaged.
- **Avoid eating, drinking and smoking in rooms where soldering work is carried out.** Otherwise, traces of lead remaining on your hands may enter the human organism via food or cigarettes.
- **Always wash your hands thoroughly after soldering work.**
- **Do not dispose of solder waste in the domestic waste.** Solder waste must be disposed of in the hazardous waste.
- **If you are carrying out soldering works on electrical components, first disconnect the power supply before starting soldering.** There is a risk of an electric shock and damages on the electrical components due to a short circuit.

Intended use

The device PSIS 11-230V is intended for soldering electrical parts in leisure and DIY sectors. It can be used for soldering works, glue welding plastics or for applying embellishments.

We recommend using the power tool with original Trotec accessories.

Foreseeable misuse

The device is not suitable for the following applications:

- for engraving electronic media such as CDs, DVDs etc. as these can be damaged during engraving.
- for hard-soldering or for soldering aluminium

Any other use than the one described in the chapter "Intended use" is regarded as reasonably foreseeable misuse.

Personnel qualifications

People who use this device must:

- have read and understood the operating manual, especially the Safety chapter.

Safety signs and labels on the accessories

Note

Do not remove any safety signs, stickers or labels from the device. Keep all safety signs, stickers and labels in legible condition.

The following safety signs and labels are attached to the accessories:



Warning of vapours hazardous to health

This symbol indicates that vapours hazardous to health can occur during soldering. Always ensure sufficient ventilation of the workplace!

Personal protective equipment



Wear eye protection.

With it you protect your eyes from splintering, falling and flying pieces which could cause injuries.

Residual risks



Warning of electrical voltage

Work on the electrical components must only be carried out by an authorised specialist company!



Warning of electrical voltage

There is a risk of a short-circuit due to liquids penetrating the housing!

Do not immerse the device and the accessories in water. Make sure that no water or other liquids can enter the housing.



Warning of electrical voltage

There is a risk of a short-circuit due to liquids penetrating the housing!

Do not use the soldering station if there are damages on the handle, the power cable or the plug. Never open the device.



Warning of hot surface

Never touch the heated soldering tip or the molten solder. Risk of burns. Always allow the device to cool down before changing, cleaning or checking components of the device.



Warning of hot surface

RISK OF INJURY! Keep your hands away from the heated workpiece. Heat can be transmitted through the workpiece.



Warning of hot surface

Some parts of this product can become very hot and cause burns. Particular attention has to be given where children and vulnerable people are present!



Warning

Toxic vapours!



During operation gases and vapours are produced which can be harmful to health.

Wear protection glasses and always ensure sufficient ventilation.



Warning

Risk of fire!

Only use the holder included in the scope of delivery or another fireproof base or mat for setting down the hot soldering iron.



Warning

Risk of fire!

Never leave the activated device unattended.

**Warning**

Avoid eating, drinking and smoking in rooms where soldering work is carried out. Otherwise, traces of lead remaining on your hands may enter the human organism via food or cigarettes.

**Warning**

Dangers can occur at the device when it is used by untrained people in an unprofessional or improper way! Observe the personnel qualifications!

**Warning**

The device is not a toy and does not belong in the hands of children.

**Warning**

Risk of suffocation!
Do not leave the packaging lying around. Children may use it as a dangerous toy.

**Caution**

Keep a sufficient distance from heat sources.

Note

If you store or transport the device improperly, the device may be damaged.
Note the information regarding transport and storage of the device.

Note

Avoid touching the hot soldering tip with the plastic parts of the holder. Otherwise the device may be damaged.

Behaviour in the event of an emergency / emergency stop function

Emergency stop:

Removing the mains plug from the mains socket results in the function of the device immediately stopping. In order to secure the device against accidental switch-on, leave the mains plug disconnected.

Behaviour in the event of an emergency:

1. Switch the device off.
2. In an emergency, disconnect the device from the mains feed-in: Hold onto the mains plug while pulling the power cable out of the mains socket.
3. Do not reconnect a defective device to the mains.

Information about the device

Device description

The device PSIS 11-230V consists of a soldering station with connected soldering iron and a soldering iron holder.

The soldering station produces temperatures of 150 °C to 500 °C at the soldering tip. The temperature can be steplessly preselected via the rotary knob on the soldering station.

The soldering tips can be replaced which allows you to adapt them to the desired application purpose (2 soldering tips included in the scope of delivery).

Storage compartments for storing soldering tips and solder are integrated in the soldering station and facilitate working.

Device depiction

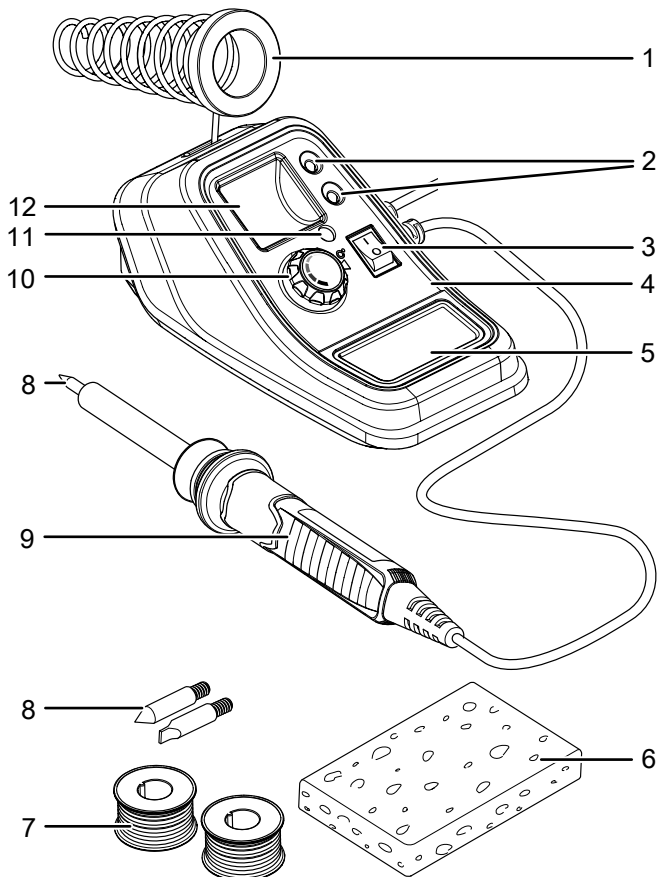

No.	Designation
1	Soldering iron holder
2	Storage compartment for soldering tips
3	On/off switch
4	Soldering station
5	Storage compartment for soldering sponge
6	Soldering sponge
7	Solder
8	Soldering tips
9	Soldering iron
10	Temperature controller
11	Indicator light
12	Storage compartment for solder

Scope of delivery

- 1 x device PSIS 11-230V
- 1 x soldering iron holder
- 2 x soldering tip
- 1 x solder Ø 1.0 mm, 10 g
- 1 x solder Ø 1.5 mm, 10 g
- 1 x soldering sponge
- 1 x Manual

Technical data

Parameter	Value
Model	PSIS 11-230V
Mains connection	230-240 V / 50 Hz
Power input	48 W
Temperature range	150 °C to 500 °C
Cable length of soldering station	2 m
Cable length of soldering iron	1 m
Protection class	I / 
Weight	0.8 kg

Transport and storage

Note

If you store or transport the device improperly, the device may be damaged.

Note the information regarding transport and storage of the device.

Transport

Before transporting the device, observe the following:

- Switch off the device.
- Hold onto the mains plug while pulling the power cable out of the mains socket.
- Allow the device to cool down.

Storage

Before storing the device, proceed as follows:

- Switch off the device.
- Hold onto the mains plug while pulling the power cable out of the mains socket.
- Allow the device to cool down.
- Clean the device as described in the Maintenance chapter.

When the device is not being used, observe the following storage conditions:

- Dry and protected from frost and heat
- Ambient temperature below 45 °C
- Protected from dust and direct sunlight

Start-up

Unpacking the device

- Take the device and the accessories out of the packaging.
- Check the contents for completeness and look for damages.



Warning

Risk of suffocation!

Do not leave the packaging lying around. Children may use it as a dangerous toy.

- Dispose of the packaging material according to the national regulations.

Inserting / changing the soldering tip



Caution

Burn hazard! Removing the soldering tip must only be performed if the device has been switched off and the soldering tip has cooled down.

The soldering tip (8) has a screw thread which allows to quickly and easily replace the soldering tip.

1. Hold onto the mains plug while pulling the power cable out of the mains socket.
2. If necessary, allow the soldering iron (9) to cool down in the soldering iron holder (1).
3. Turn the pre-mounted soldering tip (8) counter-clockwise in order to unscrew it from the soldering iron (9).

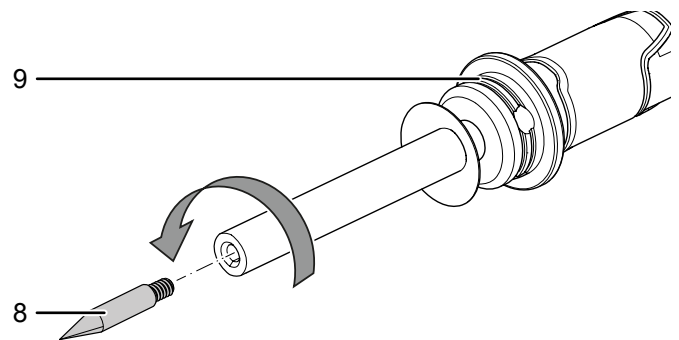

4. Turn the new soldering tip (8) clockwise into the soldering iron (9).

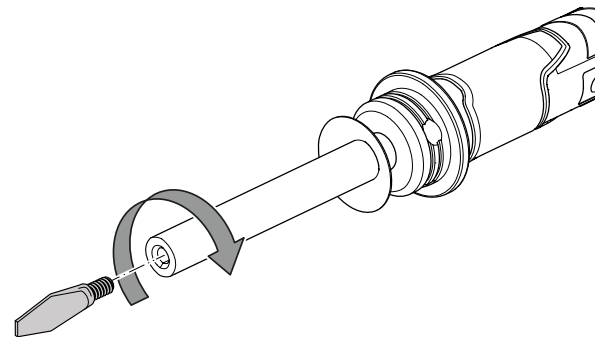

Tin-coating the soldering tip

Prior to initial start-up of the soldering station or if using a new soldering tip, the soldering tip (8) must be coated with tin.

Connecting the power cable

1. Insert the mains plug into a properly secured mains socket.

Operation

General information:

- The parts to be soldered must be clean and must not show any signs of an oxide layer. If required, remove any oxide deposits with alcohol or steel wool.
- Use a suitable mat to protect the working surface from splashes resulting from soldering.
- Avoid vibrations on the workpiece during the cooling phase. This can lead to 'cold solder joints'.
- Prior to starting soldering work, use some solder to tin-coat the clean soldering tip.
- Do not use the maximum temperature longer than absolutely necessary. This will increase the working life of your soldering tip.
- Once the solder starts melting on the soldering tip, the required temperature has been reached. If clots begin to form, the temperature is too low.
- If the soldering tip does no longer work properly, try cleaning it using fine sand paper. Afterwards, tin-coat the soldering tip again by applying some solder and soldering flux around the tip, then heat the tip.

Soldering wires together

- Use a wire stripper to remove the cable jacket.
- Twist the thin cable wires with each other, then add some solder by gently heating the cable end with the soldering iron. Due to the capillary effect, the molten solder is sucked into the twisted cable end.
- If available, use a soldering aid (helping hand) for aligning the cables next to each other.
- Using the soldering tip, heat both aligned cable ends and add further solder. Soldering has been successful once both wire ends are covered by a joint solder tin coat.

Soldering boards

- Prepare the elements to be soldered by bending the connection wires according to the holes of the breadboard.
- Insert the connection wires into the board whilst slightly bending the wires to ensure that the components are being kept in the right position.
- Heat the solder pad and the connection wire with the soldering iron, then add some solder to the heated solder joint.
- Make sure that the molten solder entirely covers the solder pad and surrounds the connection wire completely.

Switching the device on

Wear your personal protective equipment when working with the device.



Note

Make sure that there is a soldering tip in the soldering iron. Never heat the soldering iron without a soldering tip!



Note

Always use the soldering iron holder for the intervals while heating the soldering iron, for breaks between the work steps and while the soldering iron is cooling down (1).

1. Place the soldering iron (9) in the soldering iron holder (1).

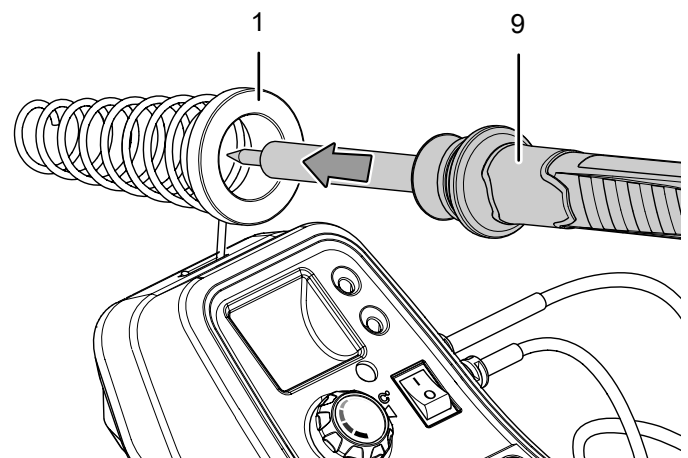

2. Set the on/off switch (3) to position "I".

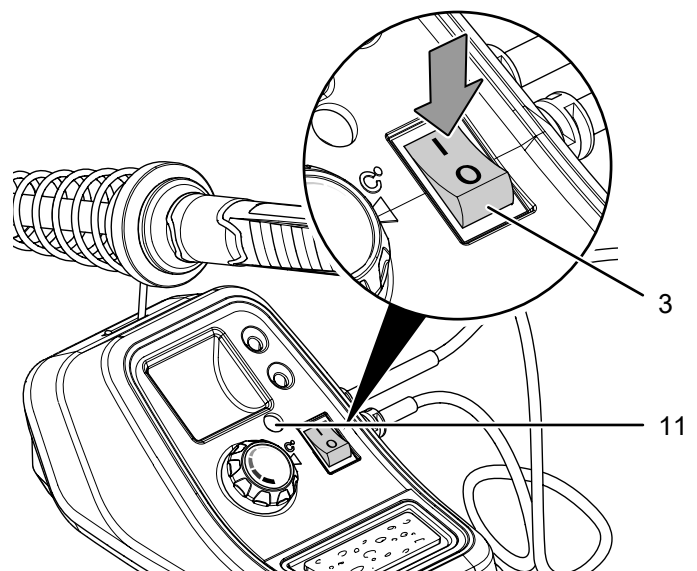

- ⇒ The indicator light (11) lights up and indicates that the device is switched on.

Setting the temperature



Note

If the soldering temperature is too low, the solder is not liquid enough. The result are cold solder joints. If the soldering temperature is too high, the solder will burn which also prevents the solder from being liquid enough. In addition, damages can be caused on the materials to be treated.

The following temperatures are used for the most common applications:

- 200 °C: Melting point of one of the most commonly used soft solders
- 300 °C: Normal operation, e.g. when using lead-free solder
- 400 °C: High temperature for soldering, e.g. for unsoldering smaller solder joints
- 500 °C: Maximum temperature for soldering, e.g. for unsoldering larger solder joints

Temperatures between 150 °C and 500 °C can be selected on the device. In order to set a specific temperature range, refer to the colour code of the temperature controller (10):

Colour code	Temperature
yellow	± 150 °C
orange	± 150 °C to 270 °C
Red	± 270 °C to 500 °C

1. Turn the temperature controller (10) clockwise to increase the temperature.
2. Turn the temperature controller (10) counter-clockwise to decrease the temperature.

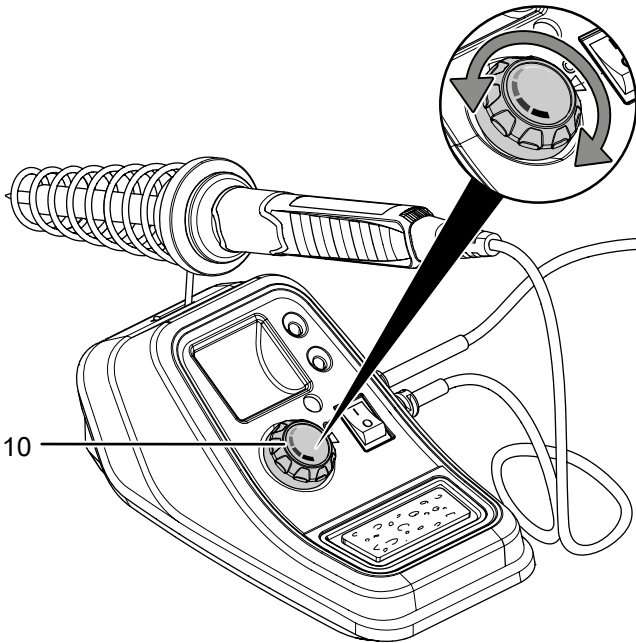

Using a soldering sponge

The soldering sponge (6) integrated in the soldering station (4) serves for cleaning the soldering tip (8).

1. Moisten the sponge (6) before using it.
2. Insert the damp soldering sponge (6) into the storage compartment (5).

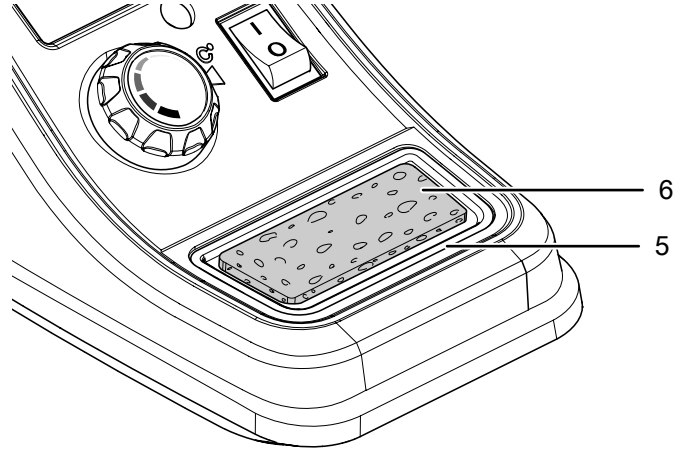

Note

The hot soldering tip must never come into contact with a dry soldering sponge. Otherwise, the soldering sponge may be damaged.

Soldering



Caution

Inhaled vapours can cause e.g. headaches and symptoms of fatigue. Always provide sufficient fresh air supply during soldering.

1. Clean the soldering tip (8) with the moistened soldering sponge (6).
2. The soldering tip has to be tin-coated after cleaning. To do so, melt some solder with the hot soldering tip.
3. Approach the soldering tip closely to the solder joint and heat it.
4. Then melt the solder between solder joint and soldering tip.
5. Add further solder until the entire solder joint is covered.
6. Remove the soldering tip to avoid overheating the molten solder.
7. Allow the solder to cool down. Avoid vibrations.



Note

Soldering flux is required to perform soldering work. The soldering flux is either part of the soldering agent or must be applied separately. Find out more about a suitable soldering agent for your intended application.

Switching the device off



Note

Always put the soldering iron back into the soldering iron holder after use.

1. Switch the on/off switch (3) to position "0".

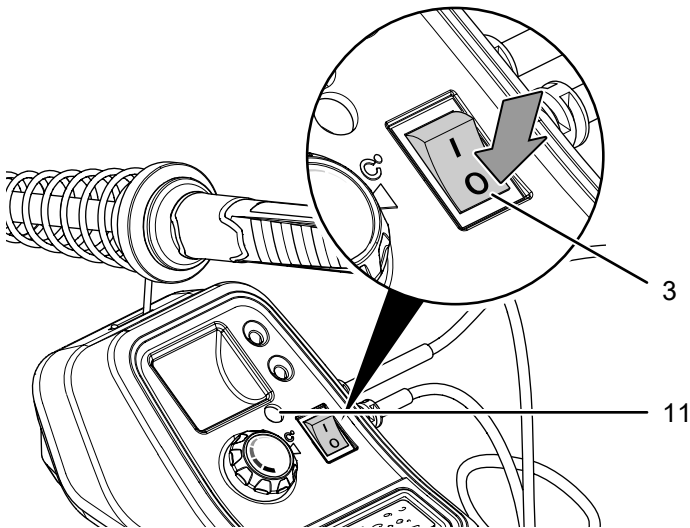

⇒ The indicator light (11) goes out.

Remove the mains plug from the mains socket if you do not use the soldering station.

Available accessories



Warning

Only use accessories and additional equipment specified in the operating manual. Using insertion tools or accessories other than those specified in the operating manual may cause a risk of injury.

Accessories	Article number
Set of soldering tips	6.236.001.001

Errors and faults

The device has been checked for proper functioning several times during production. If malfunctions occur nonetheless, check the device according to the following list.

Troubleshooting tasks which require the housing to be opened must only be carried out by an authorized specialist electrical company or by Trotec.

Light smoke or odour is emitted during the first use:

- This is not a fault. These phenomena disappear after a brief runtime.

The device does not start:

- Check the power connection.
- Check the power cable and mains plug for damage. If you notice damages, do not try to take the device back into operation.

If the supply cord is damaged, it must be replaced by the manufacturer, its service agent or similarly qualified persons in order to avoid a hazard.

- Check the on-site fusing.



Info

Wait for at least 10 minutes before switching the device back on.

The device is switched on but the solder is not liquid enough or causes cold solder joints

- The temperature of the soldering iron is too low. Check the preset temperature. If necessary, increase the temperature and wait until it has been reached.
- The temperature of the soldering iron is too high and burns either the soldering agent, cable insulations or conducting paths. Check the preset temperature. If necessary, decrease the temperature and wait until it has been reached.
- The soldering tip is soiled. Clean the soldering tip by wiping it on the moistened soldering sponge.
- The soldering tip is worn out. Insert a new soldering tip to ensure the soldering station's full power.

The solder does not joint the parts to be soldered

- The temperature of the soldering iron is too low. Check the preset temperature. If necessary, increase the temperature and wait until it has been reached.
- The solder joint is too cold. Heat the solder joint with the soldering iron. Only then add solder to ensure an even distribution.
- The workpiece has been moved during the cooling phase and a cold solder joint occurred. Make sure that the workpiece is not subject to vibrations during the cooling phase.

The device still does not operate correctly after these checks:

Please contact the customer service. If necessary, bring the device to an authorised specialist electrical company or to Trotec for repair.

Maintenance

Activities required before starting maintenance**Warning of electrical voltage**

Do not touch the mains plug with wet or damp hands.

- Switch off the device.
- Hold onto the mains plug while pulling the power cable out of the mains socket.
- Allow the device to cool down completely.

**Warning of electrical voltage**

Maintenance tasks which require the housing to be opened must only be carried out by authorised specialist companies or by Trotec.

Notes on maintenance

The device does not require maintenance.

Cleaning

The device should be cleaned before and after each use.

**Warning of electrical voltage**

There is a risk of a short-circuit due to liquids penetrating the housing!

Do not immerse the device and the accessories in water. Make sure that no water or other liquids can enter the housing.

- Clean the device with a soft, damp and lint-free cloth. Make sure that no moisture enters the housing. Protect electrical components from moisture. Do not use any aggressive cleaning agents such as cleaning sprays, solvents, alcohol-based or abrasive cleaners to dampen the cloth.
- Dry the device with a soft, lint-free cloth.
- Regularly clean the soldering tips by wiping them on the moistened soldering sponge and by tin-coating them afterwards.
- Do not use any chemicals for cleaning the soldering tips.

Disposal



The icon with the crossed-out waste bin on waste electrical or electronic equipment stipulates that this equipment must not be disposed of with the household waste at the end of its life. You will find collection points for free return of waste electrical and electronic equipment in your vicinity. The addresses can be obtained from your municipality or local administration. You can also find out about other return options that apply for many EU countries on the website <https://hub.trotec.com/?id=45090>. Otherwise, please contact an official recycling centre for electronic and electrical equipment authorised for your country.

The separate collection of waste electrical and electronic equipment aims to enable the re-use, recycling and other forms of recovery of waste equipment as well as to prevent negative effects for the environment and human health caused by the disposal of hazardous substances potentially contained in the equipment.

Trotec GmbH

Grebener Str. 7
D-52525 Heinsberg

☎ +49 2452 962-400

☎ +49 2452 962-200

info@trotec.com

www.trotec.com