

EN

INSTRUCTIONS  
CO<sub>2</sub> AIR QUALITY MONITOR

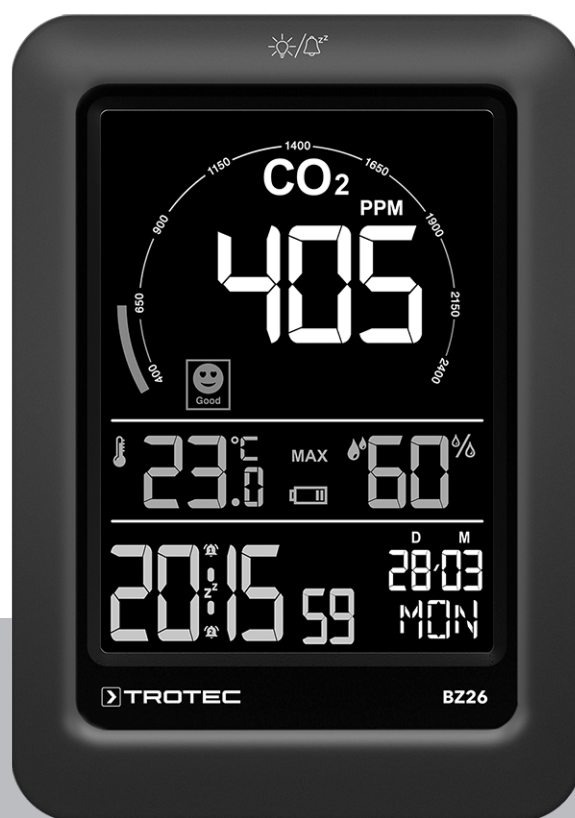

**Table of contents**

**Information on the use of these instructions** ..... 2

**Safety** ..... 2

**Information about the device** ..... 3

**Transport and storage** ..... 5

**Operation** ..... 6

**Maintenance and repair** ..... 9

**Disposal** ..... 10

**Information on the use of these instructions**

**Symbols**



**Warning of electrical voltage**

This symbol indicates dangers to the life and health of persons due to electrical voltage.



**Warning**

This signal word indicates a hazard with an average risk level which, if not avoided, can result in serious injury or death.



**Caution**

This signal word indicates a hazard with a low risk level which, if not avoided, can result in minor or moderate injury.

**Notice**

This signal word indicates important information (e.g. material damage), but does not indicate hazards.



**Info**

Information marked with this symbol helps you to carry out your tasks quickly and safely.



**Follow the manual**

Information marked with this symbol indicates that the instructions must be observed.

You can download the current version of the instructions and the EU declaration of conformity via the following link:



BZ26



<https://hub.trotec.com/?id=46639>

**Safety**

**Read this manual carefully before starting or using the device. Always store the manual in the immediate vicinity of the device or its site of use.**



**Warning**

**Read all safety warnings and all instructions.**

Failure to follow the warnings and instructions may result in electric shock, fire and/or serious injury.

**Save all warnings and instructions for future reference.**

- Do not use the device in potentially explosive rooms or areas and do not install it there.
- Do not use the device in an aggressive atmosphere.
- Do not immerse the device in water. Do not allow liquids to penetrate into the device.
- The device may only be used in dry surroundings and must not be used in the rain or at a relative humidity exceeding the operating conditions.
- Protect the device from permanent direct sunlight.
- Do not open the device.
- Do not remove any safety signs, stickers or labels from the device. Keep all safety signs, stickers and labels in legible condition.
- Use batteries of type AAA.
- Never charge batteries that cannot be recharged.
- Different types of batteries and new and used batteries must not be used together.
- Insert the batteries into the battery compartment according to the correct polarity.
- Remove discharged batteries. Batteries contain materials hazardous to the environment. Dispose of the batteries according to the national regulations.
- Remove the batteries from the device if you will not be using the device for a longer period of time.
- Never short-circuit the supply terminal in the battery compartment!

- Do not swallow batteries! If a battery is swallowed, it can cause severe internal burns within 2 hours! These burns can lead to death!
- If you think batteries might have been swallowed or otherwise entered the body, seek medical attention immediately!
- Keep new and used batteries and an open battery compartment away from children.
- Observe the storage and operating conditions (see Technical data).

### Intended use

Only use the device for air quality (CO<sub>2</sub> level), indoor temperature and humidity measurements within the measuring range specified in the technical data. Observe and comply with the technical data.

Any use other than the intended use is regarded as misuse.

### Reasonably foreseeable misuse

Do not use the device in potentially explosive atmospheres, for measurements in liquids or at live parts.

Any unauthorised modifications, alterations or structural changes to the device are forbidden.

### Personnel qualification

People who use this device must:

- have read and understood the instructions, especially the Safety chapter.

### Residual risks



#### Warning of electrical voltage

There is a risk of a short-circuit due to liquids penetrating the housing!

Do not immerse the device and the accessories in water. Make sure that no water or other liquids can enter the housing.



#### Warning of electrical voltage

Work on the electrical components must only be carried out by an authorised specialist company!



#### Warning

Risk of suffocation!

Do not leave the packaging lying around. Children may use it as a dangerous toy.



#### Warning

The device is not a toy and does not belong in the hands of children.



#### Warning

Dangers can occur at the device when it is used by untrained people in an unprofessional or improper way! Observe the personnel qualifications!



#### Caution

Keep a sufficient distance from heat sources.

#### Notice

To prevent damages to the device, do not expose it to extreme temperatures, extreme humidity or moisture.

#### Notice

Do not use abrasive cleaners or solvents to clean the device.

## Information about the device

### Device description

The CO<sub>2</sub> air quality monitor is a mains-powered measuring device with a comprehensive range of measurement options.

It comes with the following functional properties and equipment features:

- PAS measurement of carbon dioxide concentrations in the room air
- Simultaneous indication of CO<sub>2</sub> values, room temperature, humidity level, date, weekday and time
- Minimum and maximum value function for CO<sub>2</sub>, air temperature and humidity
- Carbon dioxide alarm function with acoustic alarm for a freely definable limit value
- Additional CO<sub>2</sub> indicator icon (feel-good indication)
- Automatic baseline calibration
- Manual calibration

### Automatic baseline calibration

The expected CO<sub>2</sub> fresh air value is about 400 ppm (0.04 %vol) nowadays. The device assumes this value to be the lowest limit value (baseline).

A special algorithm continuously monitors the lowest CO<sub>2</sub> value detected by the sensor over a pre-configured time interval for several days. The algorithm slowly corrects any long-term drift detected compared to the expected CO<sub>2</sub> fresh air value of 400 ppm (or 0.04 %vol).

If the device is used normally indoors, the carbon dioxide content will always drop almost to the low level of the outdoor air in the course of a week.

By recording the values over a period of 8 days and then comparing the lowest value to the 400 pm point, the device determines whether or not it needs to adjust the zero point.

The algorithm makes use of the fact that the CO<sub>2</sub> content in buildings and rooms regularly stabilizes at a minimum for a certain period of time when they are not occupied. In rooms that are continuously occupied or where there is a constantly increased CO<sub>2</sub> concentration (e.g. in greenhouses), the principle of automatic balancing therefore does not work.

**Device depiction**

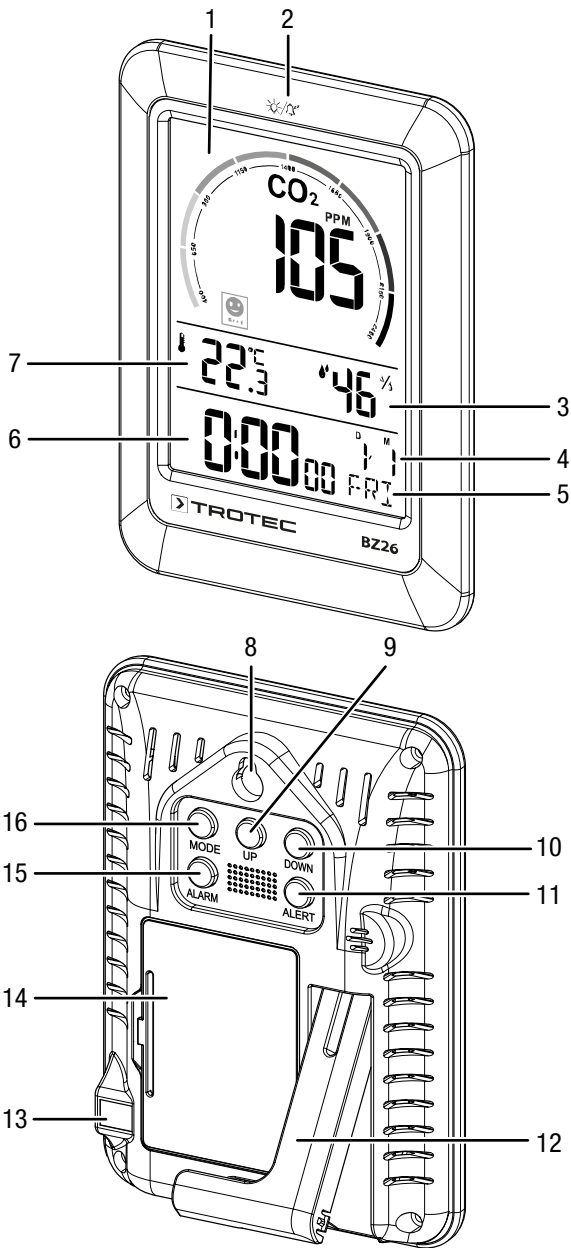

No.	Designation
1	Main display
2	Snooze/illumination sensor
3	Relative humidity indication
4	Day and month indication
5	Weekday display
6	Time indication
7	Temperature indication
8	Wall holder
9	UP button
10	DOWN button
11	ALERT button
12	Foot
13	Input of external power supply
14	Battery compartment
15	ALARM button
16	MODE button

**Main display**

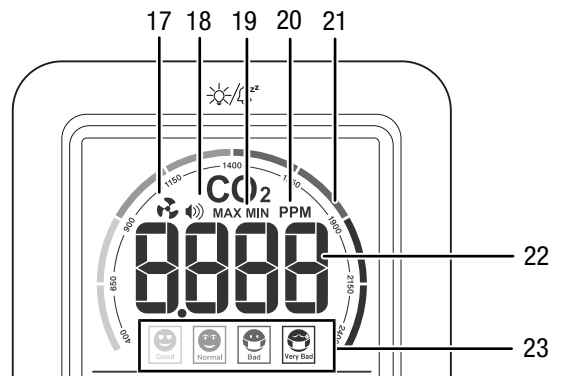

No.	Indication	Meaning
17	Ventilation	Alarm value reached.
18	Alarm	CO <sub>2</sub> alarm activated.
19	MAX/MIN	Maximum/minimum value is shown on the display.
20	PPM	Unit of the measured CO <sub>2</sub> value: parts per million (ppm)
21	Colour scale	Colour indicator of the air quality
22	CO <sub>2</sub> value	Measured CO <sub>2</sub> value
23	Feel-good indication	Air quality assessment

## Technical data

Parameter	Value
<b>Model</b>	<b>BZ26</b>
Display	LCD display
<b>Carbon dioxide (ppm)</b>	
Carbon dioxide sensor	PAS sensor (photoacoustic spectroscopy)
Measuring range	400 to 5000 ppm
Accuracy	±50 ppm + 5 %
Resolution	1 ppm
Measuring frequency carbon dioxide	every 6 seconds
<b>Relative humidity</b>	
Measuring range	20 % RH to 95 % RH
Accuracy	±5 % RH with 40 % to 80 % ±8 % RH with 20 % to 39 % and 81 % to 95 %
Resolution	1 %
Measuring frequency humidity level	every 30 seconds
<b>Air temperature</b>	
Measuring range	-9.9°C to 60°C (14.18°F to 140°F)
Accuracy	< 0 °C: ± 2°C 0 °C to 40 °C: ± 1 °C > 40 °C: ± 2°C
Resolution	0.1 °C/°F
Measuring frequency air temperature	every 30 seconds
<b>Ambient conditions</b>	
Operation	-5 °C to 50 °C (23 °F to 122 °F) and up to 90 % RH (non-condensing)
Storage	-5 °C to 50 °C (23 °F to 122 °F) and up to 90 % RH (non-condensing)
Power supply	external optionally 3 batteries 1.5 V, type AAA
Dimensions (depth x width x height)	22 mm x 89 mm x 125 mm
Weight (packaging excluded)	165 g

## Scope of delivery

- 1 x Device BZ26 (without batteries)
- 1 x USB cable
- 1 x Quick guide

## Transport and storage

### Notice

If you store or transport the device improperly, the device may be damaged.

Note the information regarding transport and storage of the device.

### Transport

When transporting the device, ensure dry conditions and protect the device from external influences e.g. by using a suitable bag.

### Storage

When the device is not being used, observe the following storage conditions:

- dry and protected from frost and heat
- protected from dust and direct sunlight
- at the temperature specified in the technical data
- Batteries are removed from the device

**Operation**



**Info**

The device can be operated using both a power adapter and batteries (3 x AAA type alkaline, 1.5 V). Due to the increased power requirement of the CO<sub>2</sub> sensor, the device is designed for permanent use with mains power, though. Via the USB cable provided, the device can therefore be supplied with power via both PC and almost any commercially available USB power adapter. During operation with mains power, the CO<sub>2</sub> measurement is activated permanently. During operation with batteries, the CO<sub>2</sub> measurement can be activated for one minute in each case, if required.



**Info**

When starting up the device for the first time, set it up in a well-ventilated room for at least one hour, enabling it to carry out a correct baseline calibration. This makes manual calibration (see chapter *Calibrating the device*) dispensable.

**Operation with batteries**

If you want to operate the device by means of batteries, batteries must be inserted into the battery compartment before you use the device for the first time:

1. Open the battery compartment at the rear of the device by sliding the cover off the device by the latch.
2. Insert three AAA 1.5 V alkaline batteries into the battery compartment with correct polarity.

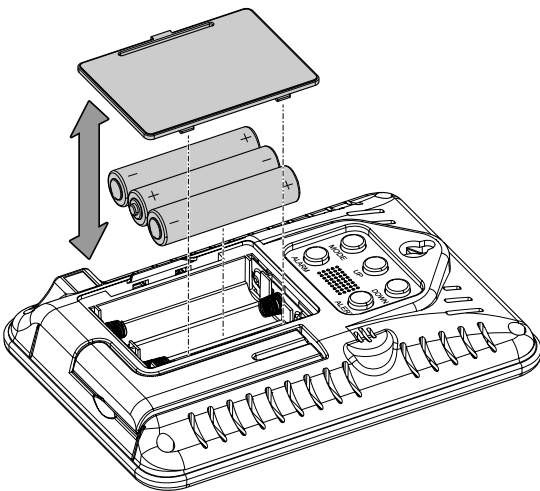

3. Reattach the cover to the battery compartment.
  - ⇒ The cover should click into place.
  - ⇒ The display will be activated and an acoustic signal is emitted. Then the device switches to the power saving mode and dims the display.

Touch the snooze/illumination sensor (2) to activate the display.

How to activate the CO<sub>2</sub> measurement function:

1. Briefly press the *DOWN* button (10).
  - ⇒ The device will start a countdown of 30 seconds.
  - ⇒ Then the device indicates the CO<sub>2</sub> value for one minute (22). During this time, the indication is updated approx. every 5 seconds.
  - ⇒ Afterwards the measured CO<sub>2</sub> value display goes out.

**Operation with power adapter**

1. To use the device, apply the provided USB cable to connect the device to the mains via a PC or a commercially available USB power adapter.

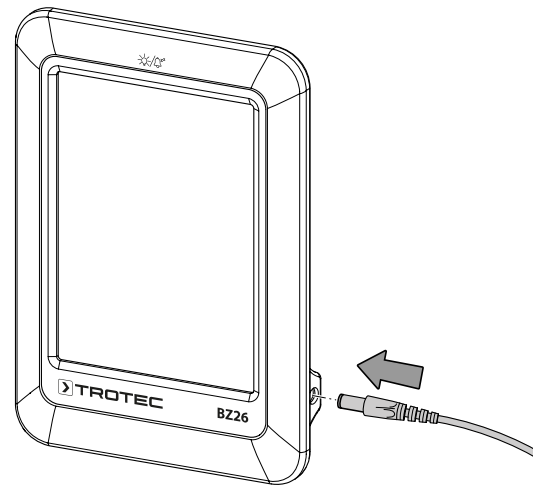

- ⇒ The display will be activated and an acoustic signal is emitted.
- ⇒ The display counts down from 60 to 1 before the CO<sub>2</sub> value is indicated. At the same time, the display indicates the temperature, humidity level and time, date and weekday.

## Operating elements

The device is operated using the following buttons.

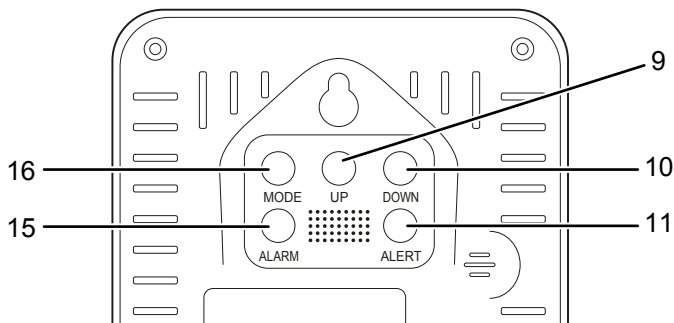

No.	Designation	Function
9	UP button	Increasing the displayed value Displaying the maximum and minimum value
10	DOWN button	Decreasing the displayed value Changing the temperature unit
11	ALERT button	Enabling/disabling/setting the CO <sub>2</sub> alarm
15	ALARM button	Enabling/disabling the alarm
16	MODE button	Opening the menu Accessing the next menu item Leaving the menu



### Info

If no button is pressed for 10 seconds, the respective settings menu is terminated.

## Setting the date and time

Press and hold the *MODE* button (16) for approx. 3 seconds to access the settings menu. Press the *MODE* button (16) briefly to move to the next setting item. You can make the following settings one after the other:

- year
- date format day/month (D M) or month/day (M D)
- month (1 to 12)
- day (1 to 31)
- hour format (12/24)
- hour (1 to 12 or 0 to 23, depending on the hour format set)
- minutes (0 to 59)

## Activating the alarm (alarm clock)

You have the option of activating two alarm times:

- AL1
- AL2

To activate the alarm, press the *ALARM* button (15). By pressing the button repeatedly, you can activate the following combinations in succession:

1. AL1 active
2. AL2 active
3. AL1 and AL2 active
4. no alarm activated

⇒ The activated alarm AL1 is indicated by the symbol (24).

⇒ The activated alarm AL2 is indicated by the symbol (25).

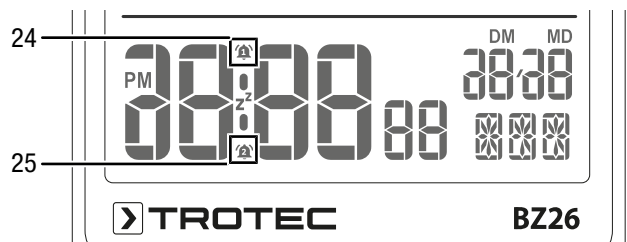

## Setting the alarm times

Please proceed as follows to set the alarm time:

1. Select the alarm to be set:
  - ⇒ Press the *MODE* button (16) once for AL1.
  - ⇒ Press the *MODE* button (16) twice for AL2.
  - ⇒ The alarm time (AL1/AL2) set previously is shown.
2. Press and hold the *MODE* button (16) for approx. 3 seconds.
  - ⇒ The hour display flashes.
3. Set the hours on the display by pressing the *UP* (9) or *DOWN* button (10).
4. Switch to the minute display by pressing the *MODE* button (16).
  - ⇒ The minute display flashes
5. Set the minutes on the display by pressing the *UP* (9) or *DOWN* button (10).
6. Exit the settings menu by pressing the *MODE* button (16).

## Turning off the alarm

When the acoustic alarm signal is emitted, you can turn it off by pressing any of the buttons (except by touching the snooze/illumination sensor (2)).

The alarm will stop automatically after 1 minute if no button is pressed.

**Snooze function**

The device comes equipped with a snooze function enabling you to pause the alarm for a short time. The function can be used as follows:

- When the alarm signal sounds, touch the snooze/illumination sensor (2).  
 ⇒ The alarm will stop and a snooze symbol (26) will flash on the display.

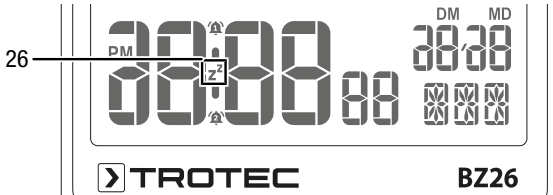

- After 5 minutes, the signal sounds again.
- Touch the snooze/illumination sensor (2) as needed to use the snooze function again.
- Turn off the snooze function by pressing any of the buttons (except by touching the snooze/illumination sensor (2)).  
 ⇒ The snooze symbol (26) will stop flashing and the snooze function is deactivated.

**Enabling the CO<sub>2</sub> alarm**

The device features an alarm function that indicates when a previously set CO<sub>2</sub> threshold is exceeded.

Please proceed as follows to enable the alarm function:

- Press the *ALERT* button (11).  
 ⇒ The alarm function is activated and the *Alarm* indication (18) appears.  
 ⇒ As soon as the measured value exceeds the previously set limit value, an acoustic alarm signal is emitted and the *Ventilation* indication (17) flashes.
- Press the button again to disable the CO<sub>2</sub> alarm.  
 ⇒ The alarm function is deactivated and the *Alarm* indication (18) disappears.  
 ⇒ If the measured value exceeds the limit value while the alarm function is deactivated, the *Ventilation* indication (17) will flash.



**Info**

The alarm limit value is set to 1000 ppm by default.

**Setting the threshold value for the CO<sub>2</sub> alarm**

Please proceed as follows to set a new limit value:

- Press and hold the *ALERT* button (11) for approx. 3 seconds.  
 ⇒ The limit value set previously appears and flashes on the display.
- Set the limit value for the CO<sub>2</sub> alarm by pressing the *UP* (9) or *DOWN* button (10).
- Press the *ALERT* button (11) again to confirm the new limit value.  
 ⇒ The display of the limit value goes out.  
 ⇒ The value shown most recently is set as the new limit value.

**Feel-good indication and colour scale**

The device is equipped with a colour scale (21) and feel-good indication (23) to illustrate the effect of the indicated measured CO<sub>2</sub> value on humans.

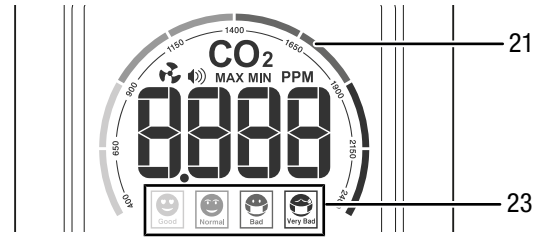

The feel-good indication consists of the following four symbols:

Symbol	Colour	CO <sub>2</sub> value	Air quality
	dark green	400 to 650 ppm	decent
	light green	651 to 900 ppm	normal
	red	901 to 1650 ppm	poor
	dark red	1651 to 5000 ppm and higher	very poor

**Showing the MAX/MIN values**



**Info**

The maximum and minimum values apply for one day. At 00:00, the current values are deleted.

To show the maximum and minimum values for the CO<sub>2</sub> value, air temperature and humidity, proceed as follows:

- Press the *UP* button (9).  
 ⇒ The display shows the maximum values of CO<sub>2</sub> value, air temperature and humidity.
- Then press the *UP* button (9) again.  
 ⇒ The display shows the minimum values of CO<sub>2</sub> value, air temperature and humidity.
- Press the *UP* button (9) again to switch to the indication of the current values.

To delete the maximum and minimum values manually, press the *UP* button (9) for approx. 2 seconds.

**Adjusting the brightness level of the display**

Touch the snooze/illumination sensor (2) to adjust the brightness level of the display. You can select the following levels one after the other:

- 100 % brightness
- 30 % brightness
- 1 % brightness



**Info**

In mere battery operation, the display is dimmed again to a brightness level of 1 % after 10 seconds in order to save energy.



### Switching the temperature indication between °C and °F

Press and hold the *DOWN* button (10) for approx. 3 seconds to switch the unit of the temperature indication between °C and °F.

### Device calibration

The device is provided with an automatic baseline calibration function which carries out automatic calibration every 7 days. You also have the option to calibrate the device manually.

Observe the following for carrying out manual calibration:

- Carry out the calibration in an ambient CO<sub>2</sub> concentration of approx. 400 ppm. Outdoors, this is most likely to be expected on a clear, sunny day. Never carry out manual calibration in an environment with an actual CO<sub>2</sub> concentration that is not known to you.
- Do not carry out the calibration on rainy days, since the high humidity level has an impact on the CO<sub>2</sub> concentration.
- Do not carry out the calibration in places with large volumes of persons, places with a high CO<sub>2</sub> concentration or near open fires or exhaust outlets.
- When carrying out the calibration, keep away from animals, humans or plants, since they may affect the CO<sub>2</sub> concentration.
- Keep away from perfumes, paints/lacquers, air fresheners, cigarette smoke, alcohol, chemical substances, etc., as they may distort the measurement results.
- Recalibrate the device if you determine unrealistic measured values.

Please proceed as follows for manual calibration:

1. Disconnect the device from the mains cable plug and remove the batteries from the device if the device contains batteries.
2. Simultaneously press and hold the *MODE* (16) and *DOWN* (10) buttons.
3. Connect the device to the mains cable plug again while keeping the buttons pressed.
4. Keep the *MODE* button (16) and *DOWN* button (10) pressed simultaneously for approx. 3 seconds to enable manual mode for the calibration.
  - ⇒ An acoustic signal is emitted.
  - ⇒ The indication *CAL* will flash on the display and the manual calibration process that takes approx. 4 minutes will start.
  - ⇒ You can now let go of the two buttons.
  - ⇒ After successful calibration, the indication *PASS* will show on the display. Then the CO<sub>2</sub> value is displayed again.
  - ⇒ If the calibration has failed, the display will show the indication *ERR*. In this case, carry out a new calibration.
5. Remove the mains plug from the device.
6. Plug the mains plug back into the device and/or reinsert the batteries.
  - ⇒ The calibration is complete.

### Switching the device off

Disconnect the device from the mains cable plug and remove the batteries to switch off the device.

## Maintenance and repair

### Battery change

A battery change is required when the battery symbol is indicated on the display or if the display itself is no longer or only partly visible.

If a CO<sub>2</sub> measurement is enabled during battery operation (see *Operation with batteries*), no CO<sub>2</sub> measurement can be carried out when the battery voltage is low. Instead of the measured CO<sub>2</sub> value, the indication *LO* will appear on the display. In this case, replace the batteries immediately.



#### Info

Changing the batteries while the device is not supplied with electricity will cause a loss of the settings. Before changing the batteries, connect the device to a power source via the USB cable, in order to prevent the settings from being deleted when the batteries are changed.

Carry out the battery change as described in the *Operation with batteries* chapter.

### Cleaning

Clean the device with a soft, damp and lint-free cloth. Make sure that no moisture enters the housing. Do not use any sprays, solvents, alcohol-based cleaning agents or abrasive cleaners, but only clean water to moisten the cloth.

### Repair

Do not modify the device or install any spare parts. For repairs or device testing, contact the manufacturer.

## Disposal

Always dispose of packing materials in an environmentally friendly manner and in accordance with the applicable local disposal regulations.



The icon with the crossed-out wheeled bin indicates that this device and any associated components (e.g. remote controls) must not be disposed of with household waste at the end of their life, in accordance with the Waste Electrical and Electronic Equipment Directive (2012/19/EU) and national laws.

You will find collection points for free return of waste electrical and electronic equipment in your vicinity. The addresses can be obtained from your municipality or local administration. You can also find out about other return options that apply for many EU countries on the website <https://hub.trotec.com/?id=45090>. Otherwise, please contact an official recycling centre for electronic and electrical equipment authorised for your country.

The separate collection of waste electrical and electronic equipment aims to enable the re-use, recycling and other forms of recovery of waste equipment as well as to prevent negative effects for the environment and human health caused by the disposal of hazardous substances potentially contained in the equipment.



This icon with the crossed-out wheeled bin indicates that batteries or accumulators must not be disposed of with household waste at the end of their life. If the device contains batteries or accumulators that contain mercury, cadmium or lead, the respective chemical symbol (Hg, Cd or Pb) is shown below the icon of the crossed-out wheeled bin. To prevent environmental pollution, do not carelessly leave batteries or electrical and electronic equipment containing batteries in public areas. In the European Union, batteries and accumulators must be returned to a designated collection point in accordance with REGULATION (EU) 2023/1542 OF THE EUROPEAN PARLIAMENT AND OF THE COUNCIL of 12 July 2023 concerning batteries and waste batteries. Remove batteries/accumulators and dispose of them separately according to the relevant legal requirements.

### Only for United Kingdom

According to Waste Electrical and Electronic Equipment Regulations 2013 (SI 2013/3113) (as amended) devices that are no longer usable must be collected separately and disposed of in an environmentally friendly manner.

Trotec GmbH

Grebbener Str. 7  
D-52525 Heinsberg

📞 +49 2452 962-400

📠 +49 2452 962-200

[info@trotec.com](mailto:info@trotec.com)

[www.trotec.com](http://www.trotec.com)