



## Original instructions

AC 7000

---

| en |



## Table of contents

|   |           |
|---|-----------|
| <b>Information on the use of these instructions</b> .....   | <b>4</b>  |
| Symbols.....  | 4         |
| <b>Safety</b> .....   | <b>5</b>  |
| Intended use .....  | 7         |
| Reasonably foreseeable misuse.....                          | 7         |
| Personnel qualification.....                                | 7         |
| Personal protective equipment.....                          | 7         |
| Safety signs and labels on the device .....                 | 8         |
| Residual risks .....  | 8         |
| Behaviour in the event of an emergency .....                | 10        |
| <b>Information about the device</b> .....                   | <b>11</b> |
| Device description .....                                    | 11        |
| Device depiction.....                                       | 12        |
| <b>Transport and storage</b> .....                          | <b>14</b> |
| Transport.....  | 14        |
| Storage .....   | 14        |
| <b>Assembly and start-up</b> .....                          | <b>15</b> |
| Scope of delivery .....                                     | 15        |
| Unpacking the device.....                                   | 15        |
| Start-up .....  | 15        |
| <b>Operation</b> .....                                      | <b>19</b> |
| <b>Available accessories</b> .....                          | <b>30</b> |
| <b>Errors and faults</b> .....                              | <b>31</b> |
| <b>Maintenance</b> .....                                    | <b>33</b> |
| Maintenance intervals .....                                 | 33        |
| Maintenance and care log .....                              | 33        |
| Safety instructions for maintenance .....                   | 34        |
| Safety signs and labels on the device .....                 | 35        |
| Cleaning the housing .....                                  | 35        |
| Visual inspection of the inside of the device for dirt..... | 35        |
| Cleaning the air filter.....                                | 36        |
| Venting the outdoor unit.....                               | 36        |
| Checking and topping up the water / glycol mixture .....    | 37        |
| Activities required after maintenance.....                  | 38        |
| <b>Technical annex</b> .....                                | <b>39</b> |
| Technical data .....  | 39        |
| <b>Disposal</b> .....                                       | <b>48</b> |
| <b>EU Declaration of Conformity</b> .....                   | <b>49</b> |

## Information on the use of these instructions

### Symbols



#### **Danger**

This symbol indicates dangers to the life and health of persons due to flammable refrigerants.



#### **Warning of electrical voltage**

This symbol indicates dangers to the life and health of persons due to electrical voltage.



#### **Warning**

This signal word indicates a hazard with an average risk level which, if not avoided, can result in serious injury or death.



#### **Caution**

This signal word indicates a hazard with a low risk level which, if not avoided, can result in minor or moderate injury.

#### **Notice**

This signal word indicates important information (e.g. material damage), but does not indicate hazards.



#### **Info**

Information marked with this symbol helps you to carry out your tasks quickly and safely.



#### **Follow the manual**

Information marked with this symbol indicates that the instructions must be observed.



#### **Wear safety glasses**

Information marked with this symbol indicates that you should wear eye protection.



#### **Wear a protective mask**

Information marked with this symbol indicates that you should wear a protective mask.



#### **Wear protective gloves**

Information marked with this symbol indicates that you should wear protective gloves.



#### **Wear foot protection**

Information marked with this symbol indicates that you should wear safety boots.

You can download the current version of these instructions via the following link:

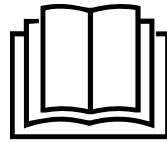

AC 7000



en

<https://www.danthermgroup.com/uk/products/dantherm-ac-7000>

## Safety



### **Warning**

#### **Read all safety warnings and all instructions.**

Failure to follow the warnings and instructions may result in electric shock, fire and/or serious injury.

#### **Save all warnings and instructions for future reference.**

This appliance can be used by children aged from 8 years and above and persons with reduced physical, sensory or mental capabilities or lack of experience and knowledge if they have been given supervision or instruction concerning use of the appliance in a safe way and understand the hazards involved.

Children shall not play with the appliance. Cleaning and user maintenance shall not be done by children without supervision.

- Do not use the device in potentially explosive rooms or areas and do not install it there.
- Do not use the device in an aggressive atmosphere.
- Place the device in an upright and stable position on a horizontal and stable surface.
- Never drink the water / glycol mixture! Dispose of the water / glycol mixture properly.
- Fill the tank with the water / glycol mixture only.
- Let the device dry out after a wet clean. Do not operate it when wet.
- Do not use the device with wet or damp hands.
- Do not expose the device to directly squirting water.
- Never insert any objects or limbs into the device.
- Do not cover the device during operation.
- Do not sit on the device.
- This appliance is not a toy. Keep away from children and animals.
- Check accessories and connection parts for possible damage prior to every use of the device. Do not use any defective devices or device parts.
- Ensure that all electric cables outside of the device are protected from damage (e.g. caused by animals). Never use the device if electric cables or the power connection are damaged!
- The mains connection must correspond to the specifications in the Technical annex.
- Insert the mains plug into a properly fused mains socket.

- Observe the technical data when selecting extensions to the power cable. Completely unroll the extension cable. Avoid electrical overload.
- Before carrying out maintenance, care or repair work on the device, remove the mains plug from the mains socket. Hold onto the mains plug while doing so.
- Switch the device off and disconnect the power cable from the mains socket when the device is not in use.
- Do not under any circumstances use the device if you detect damages on the mains plug or power cable.  
If the supply cord is damaged, it must be replaced by a special cord or assembly available from the manufacturer or its service agent.  
Defective power cables pose a serious health risk!
- When positioning the device, observe the minimum distances from walls and other objects as well as the storage and operating conditions specified in the Technical annex.
- Make sure that the air inlet and outlet are not obstructed.
- Do not remove any safety signs, stickers or labels from the device. Keep all safety signs, stickers and labels in legible condition.
- Discharge the collected condensate before transport and storage. Do not drink it. Health hazard!
- Only transport the device in an upright position.
- Only use original spare parts, for otherwise safe and functional operation cannot be ensured.
- Only install the device in compliance with the national installation regulations.
- Only install, operate and store the device AC 7000 in a room measuring more than 4 m<sup>2</sup>.
- Store the device in a way that no mechanical damage can occur.
- The entire refrigerant circuit is a maintenance-free, hermetically sealed system and may only be maintained or repaired by specialist companies for cooling and air-conditioning or by the manufacturer.

**Safety instructions for servicing the refrigerant circuit:**

- Every person working with or at the refrigerant circuit must be able to provide a certificate of qualification issued by a body accredited by the industry, demonstrating their competence in the safe use of refrigerants based on a procedure well-known in the industry.
- Service work may only be carried out in accordance with the manufacturer's specifications. If maintenance and repair work require the support of additional persons, the person trained in handling flammable refrigerants shall continuously supervise the work carried out.
- Do not use any means other than those recommended by the manufacturer for accelerating the defrosting process.
- Do not drill into or burn.
- Please note that the refrigerant is odourless.
- Observe the national regulations for gas installations.
- Observe the maximum refrigerant capacity in the technical data.

## Intended use

Only use the device for cooling or circulating indoor air whilst adhering to the technical data.

Any use other than the intended use is regarded as misuse.

## Reasonably foreseeable misuse

- Do not place the device on wet or flooded ground.
- Do not place any objects, e.g. clothing, on the device.
- Do not use the basic device outdoors.
- Never immerse the device in water.
- Do not make any unauthorised modifications, alterations or structural changes to the device.

## Personnel qualification

People who use this device must:

- be aware of the dangers that occur when working with electric devices in damp areas.
- have read and understood the instructions, especially the Safety chapter.

Maintenance tasks which require the housing to be opened must only be carried out by specialist companies for cooling and air-conditioning or by the manufacturer.

## Personal protective equipment



### **Wear safety glasses**

For start-up, maintenance and troubleshooting always wear suitable safety glasses.



### **Wear a protective mask**

For cleaning and maintenance tasks wear an appropriate protective mask.



### **Wear protective gloves**

For start-up, maintenance and troubleshooting always wear suitable protective gloves.



### **Wear foot protection**

For transportation, start-up, maintenance and troubleshooting always wear suitable foot protection.

## Safety signs and labels on the device

### Notice

Do not remove any safety signs, stickers or labels from the device. Keep all safety signs, stickers and labels in legible condition.



The following safety signs and labels are attached to the device:

**WARNING • WARNUNG • ATTENTION**

**DE** Das Gerät muss in einem Raum mit einer Grundfläche größer als 4 m<sup>2</sup> aufgestellt, betrieben und gelagert werden.

**EN** Appliance shall be installed, operated and stored in a room with floor area larger than 4 m<sup>2</sup>.

**FR** L'appareil doit être installé, utilisé et entreposé dans une pièce avec une surface supérieure à 4 m<sup>2</sup>.

#### Follow the manual

This symbol indicates that the instructions must be observed.



#### Follow the repair manual

Disposal, maintenance and repair work of the refrigerant circuit may only be carried out in accordance with the manufacturer's specifications and by persons having a certificate of qualification. A corresponding repair manual is available from the manufacturer upon request.

## Residual risks



### **⚠ Danger**

#### Refrigerant R454C!

H221 – Flammable gas.

H280 – Contains gas under pressure; may explode if heated.

P210 – Keep away from heat, sparks, open flames and other ignition sources. No smoking.

P377 – Leaking gas fire; Do not extinguish, unless leak can be stopped safely.

P381 – Eliminate all ignition sources if safe to do so.

P410 and P403 – Protect from sunlight. Store in a well-ventilated place.



### **Danger**

#### **Risk of injury from contact with glycol!**

Contact with the escaping water / glycol mixture can cause severe eye irritation and internal injuries when swallowed (e.g. kidney damage).

Avoid contact with the water / glycol mixture.

Never drink the water / glycol mixture!

Always wear safety glasses, protective gloves and tight-fitting work clothing.

In case of contact with eyes: Rinse carefully with water for some minutes. Remove contact lenses, if applicable. Continue rinsing.

Remove any escaping liquid.

Observe the relevant safety data sheets.



### **Warning of electrical voltage**

Work on the electrical components must only be carried out by an authorised specialist company!



### **Warning of electrical voltage**

Before any work on the device, remove the mains plug from the mains socket!

Do not touch the mains plug with wet or damp hands.

Hold onto the mains plug while pulling the power cable out of the mains socket.



### **Warning**

Dangers can occur at the device when it is used by untrained people in an unprofessional or improper way! Observe the personnel qualifications!



### **Warning**

The device is not a toy and does not belong in the hands of children.



### **Warning**

Risk of suffocation!

Do not leave the packaging lying around. Children may use it as a dangerous toy.

### **Notice**

To avoid damages to the device, only transport and operate the device in an upright position! It must neither be tilted nor laid down!

### **Notice**

Do not operate the device without an inserted air filter! Without the air filter, the inside of the device will be heavily contaminated. This could reduce the performance and result in damage to the device.

## **Behaviour in the event of an emergency**

1. Switch the device off.
2. Disconnect the device from the mains by removing the mains plug from the socket. When doing so, be sure to hold the plug, not the cable.
3. Do not reconnect a defective device to the mains.

## Information about the device

### Device description

The device is an air conditioner with two cooling circuits. The refrigerant circuit of the basic device is self-contained. For the dissipation of warmth, the room air is channelled through the fan via a heat exchanger. The refrigerant absorbs the heat and cools the room air. In another heat exchanger, the heat from the refrigerant circuit is transferred to the second cooling circuit. The resulting heated water / glycol mixture is transported to the heat exchanger of the outdoor unit, where it transfers the heat to the outdoor air. Condensate produced in the basic device is drained via a hose to the outdoor unit where it evaporates.

## Device depiction

### Basic device

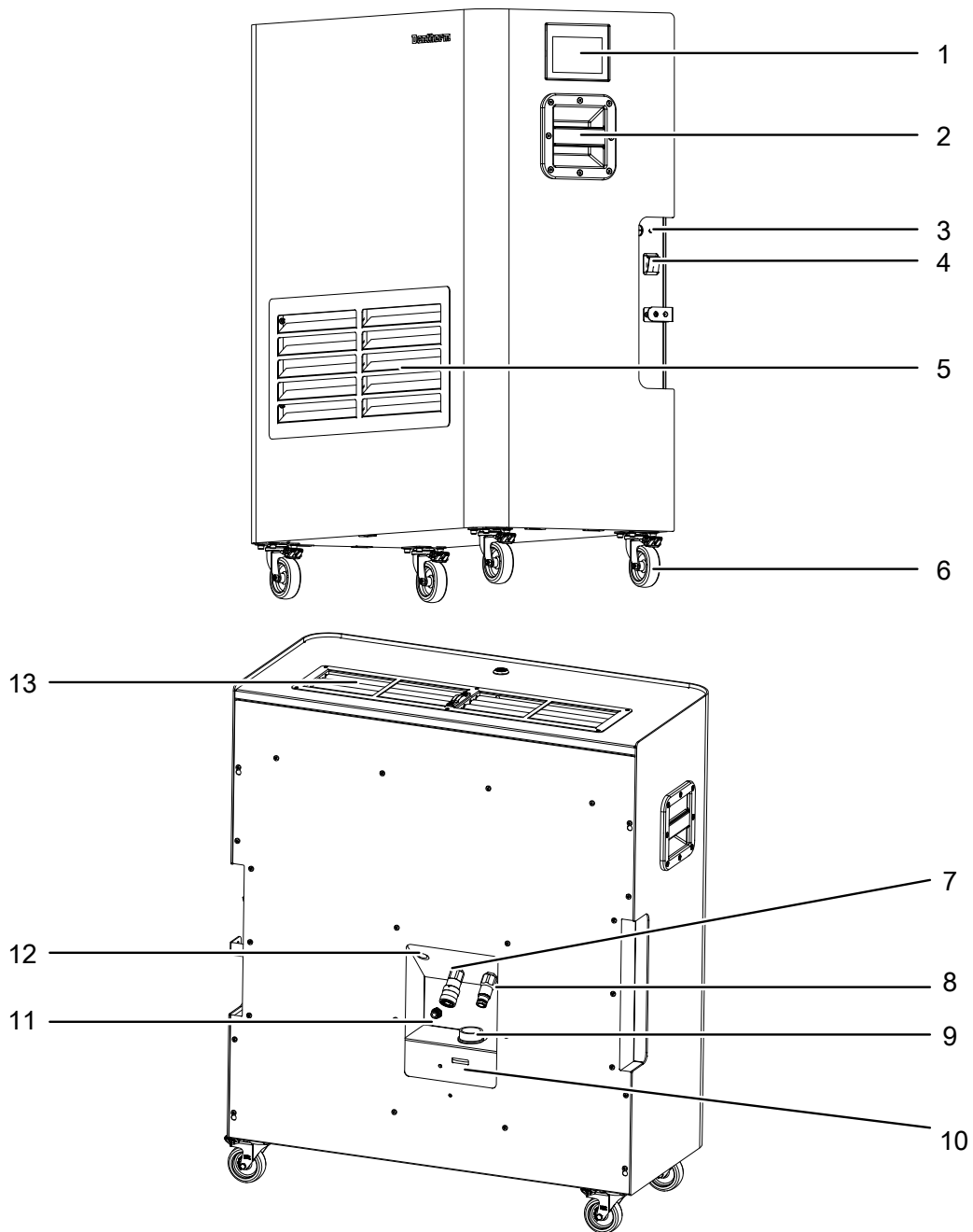

| No. | Designation                                     | No. | Designation   |
|-----|---|-----|---|
| 1   | Control panel                                   | 8   | Cooling circuit connection to outdoor unit (OUT)    |
| 2   | Transport handle                                | 9   | Tank for water / glycol mixture                     |
| 3   | Mains connection                                | 10  | Filling level indication for water / glycol mixture |
| 4   | Main switch                                     | 11  | Connection for condensation hose                    |
| 5   | Air inlet with air filter                       | 12  | Connection cable to outdoor unit                    |
| 6   | Wheels  | 13  | Air outlet  |
| 7   | Cooling circuit connection to outdoor unit (IN) |     |   |

**Outdoor unit**

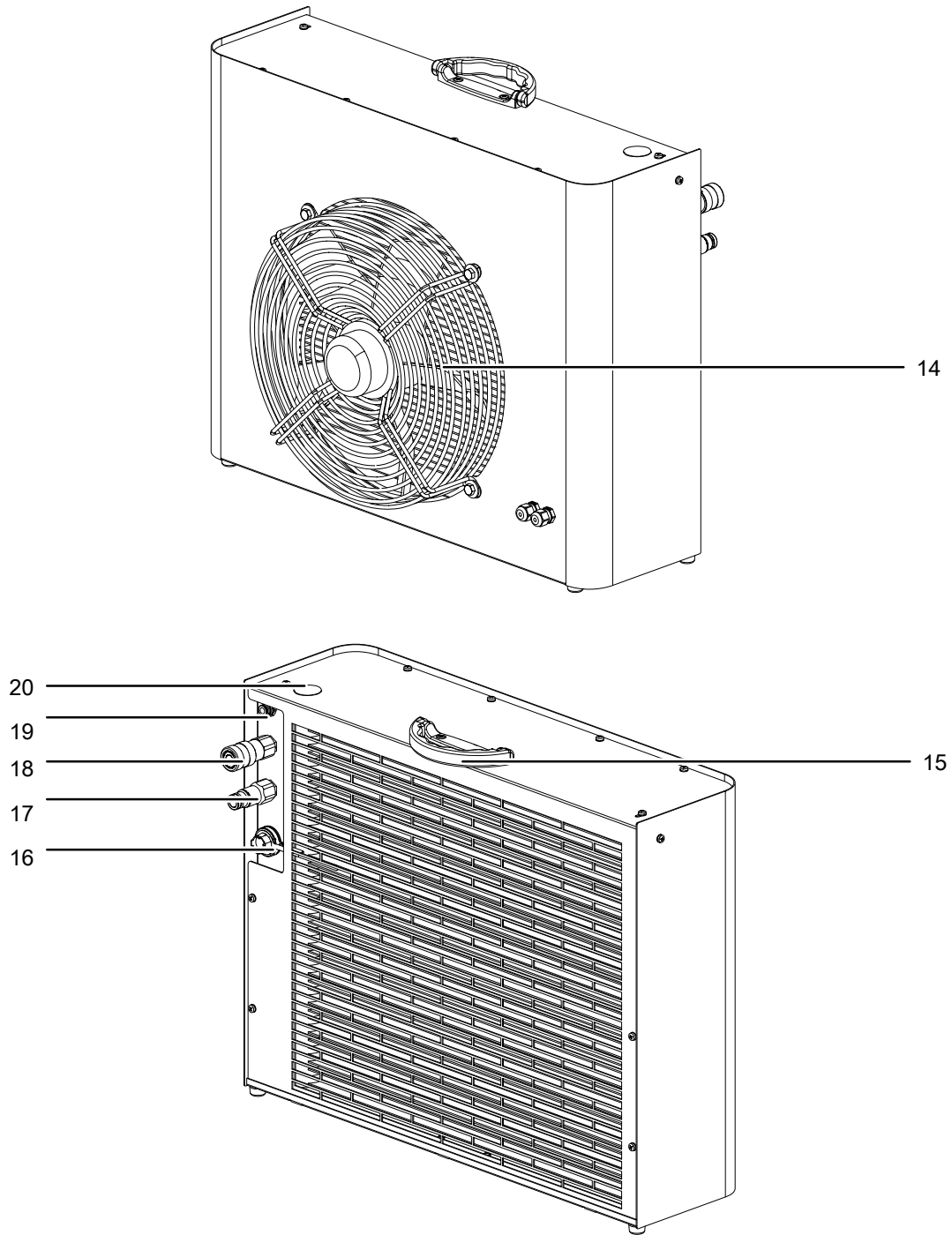

| No. | Designation                                      | No. | Designation                                     |
|-----|--|-----|---|
| 14  | Fan  | 18  | Cooling circuit connection to basic device (IN) |
| 15  | Transport handle                                 | 19  | Connection for condensation hose                |
| 16  | Connection cable to basic device                 | 20  | Bleed screw for water / glycol mixture          |
| 17  | Cooling circuit connection to basic device (OUT) |     |   |

## Transport and storage

### Notice

If you store or transport the device improperly, the device may be damaged.

Note the information regarding transport and storage of the device.

## Transport



### Wear foot protection

For transportation, start-up, maintenance and troubleshooting always wear suitable foot protection.

Please note that additional transport regulations might apply to devices containing flammable refrigerants. The equipment's arrangement and the maximum number of components to be transported together can be gathered from the applicable transport regulations.

**Before** transporting the device, observe the following:

- Take the device out of operation (see Operation chapter).
- Allow the water / glycol mixture to cool down.
- Release the brakes on the transport castors (6).

**While** transporting the device, observe the following:

- Do not use the power cable to drag the device.
- Transport the device in an upright position.
- The basic device is positioned on four movable transport castors and can be rolled by one person. The transport handles (2) attached to the side can be used to hold on to when rolling the device. Only roll the device on a level and smooth surface. If you want to lift and transport the device with a pallet jack or forklift, seek assistance from at least one other person.
- The outdoor unit can be carried by one person via the transport handle (15).

**After** transporting the device, proceed as follows:

- Set up the device in an upright position after transport.
- Apply the brakes on the transport castors (6) again.

## Storage

**Before** storing the device, proceed as follows:

- Take the device out of operation (see Operation chapter).

When the device is not being used, observe the following storage conditions:

- Only store the device in a room measuring more than 4 m<sup>2</sup>.
- Only position the device in rooms where there is no source of ignition (e.g. open flames, an active gas appliance or an electric heater).
- Store the device in a dry location and protected from frost and heat.
- Store the device in an upright position where it is protected from dust and direct sunlight.
- If required, use a cover to protect the device from invasive dust.
- Place no further devices or objects on top of the device to prevent it from being damaged.

## Assembly and start-up

### Scope of delivery

- 1 x Basic device
- 1 x Outdoor unit
- 1 x Standard hose set (incl. 1 x condensation hose, 2 x hose for water / glycol circuit, 1 x electrical connection cable)
- 1 x Mains cable with mains plug (for basic device)
- 1 x Manual

### Unpacking the device

1. Open the package and remove the outdoor unit and the basic device.
2. Remove the packaging completely from the outdoor unit and the basic device.
3. Remove the hose set and the power cable. Ensure that the basic device, outdoor unit, cables and hoses are not damaged.

### Start-up

When positioning the device, observe the minimum distance from walls or other objects as described in the Technical data chapter.

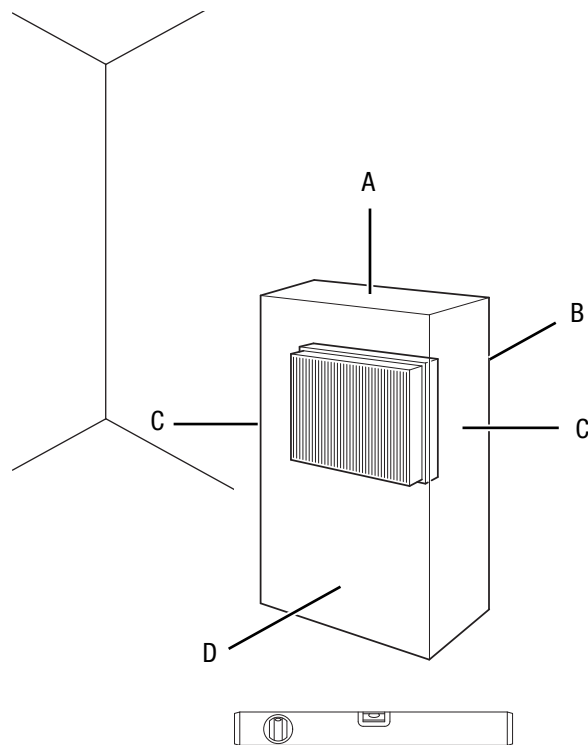

### Installing the basic device

Before installing the device, observe the following:

- Only position the device in rooms where potentially leaking refrigerant cannot accumulate.
- Before restarting the device, check the condition of the power cable. If there are doubts as to the sound condition, contact the customer service.
- Place the device in an upright and stable position on a horizontal and stable surface.
- Check whether the brakes on the transport castors of the basic device (6) are engaged.

- Do not create tripping hazards when laying the power cable or other electric cables, especially when positioning the device in the middle of the room. Use cable bridges.
- Make sure that extension cables are completely unrolled.
- Ensure that the air inlet and outlet are not obstructed.
- Make sure that no curtains or other objects interfere with the air flow.

### Installing the outdoor unit

#### Notice

Please note that the outdoor unit requires a minimum distance of 3 m to the front from the nearest wall or other objects.

#### Notice

During operation, the outdoor unit should be either lower or a maximum of 8 metres higher than the basic device. When refilling the water / glycol mixture, the outdoor unit must be placed either in a lower position or at the same level as the basic device.

Before installing the device, observe the following:

- Place the device in an upright and stable position on a horizontal and stable surface.

### Inserting the air filter

#### Notice

Do not operate the device without an inserted air filter! Without the air filter, the inside of the device will be heavily contaminated. This could reduce the performance and result in damage to the device.

1. Loosen the two screws (22) at the top left and right of the ventilation plate at the air inlet (5).
2. Remove the ventilation plate from the air inlet (5) and check whether the air filter (21) is already fitted.

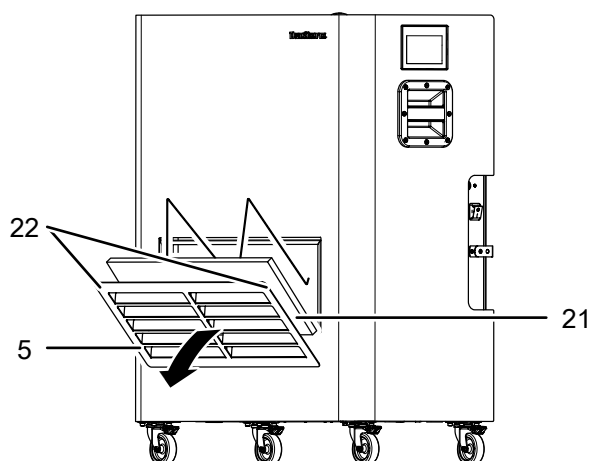

3. If the air filter (21) has not yet been fitted, push the air filter (21) into the filter insert and then into the designated recess.
4. Refit the ventilation plate at the air inlet (5) and fasten the ventilation plate using the two screws (22) at the top left and right.

**Connecting basic device and outdoor unit**



**Wear safety glasses**



**Wear protective gloves**



**Info**

Both the basic device and the outdoor unit are equipped with flat-face couplings. This enables leakage-free connecting and disconnecting with very little effort.

**Notice**

If the basic device and outdoor unit are installed on a sensitive surface, protect it with appropriate covers during installation.



**Info**

The hose set is 10 metres long. You can use a maximum of 3 hose sets and thus extend the length to 30 metres. The electrical connection cable for the basic device and outdoor unit is also 10 metres long.



**Info**

The hose set has two different ends. The side for the connection to the basic device is fitted with a male plug, the side for the connection to the outdoor unit has a female plug.

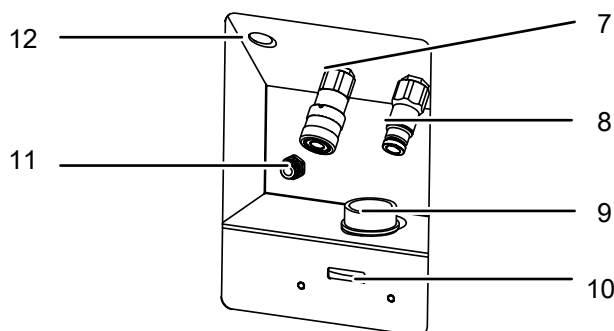
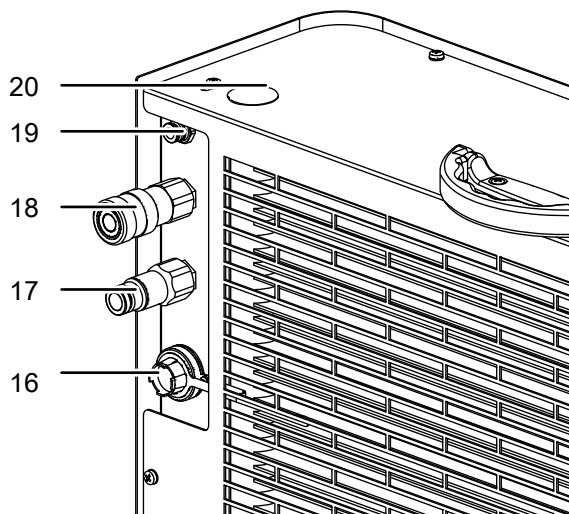

1. Connect the electric cable from the hose set to the connection (12) on the basic device.
2. Connect the two water / glycol lines to the connections 7 and 8.
3. Attach the condensation hose to connection 11.
4. Place the other end of the hose set to the outdoor unit. If necessary, extend the hose set with one or a maximum of two additional hose sets.
5. Connect the outdoor unit to the hose set (electrical cable, two water / glycol lines, condensation hose).
6. Check whether the amount of water / glycol mixture in the tank (9) is sufficient and top it up if necessary (see "Checking and topping up the water / glycol mixture" in the Maintenance chapter).

**Connecting the power cable**



**⚠ Warning of electrical voltage**

Do not touch the mains plug with wet or damp hands.

Hold onto the mains plug while plugging the power cable into the mains socket.

1. Plug the power cable into the mains connection (3) of the basic device.
2. Insert the mains plug into a properly fused mains socket.

## Operation

### Notice

If the device has been moved, allow it to stand for 30 minutes before using it again so that the lubricating oil can flow back into the compressor. Acting contrary might lead to compressor damage and a malfunctioning device.



### Info

Avoid open doors and windows so that the cooling function of the basic device is not impaired.

### Switching the device on

Once you have completely installed the device as described in the Start-up chapter, you can switch it on.

Please proceed as follows to switch the device on:

1. Set the main switch (4) to position I.

⇒ The control panel lights up and the device initialises automatically while displaying the following:



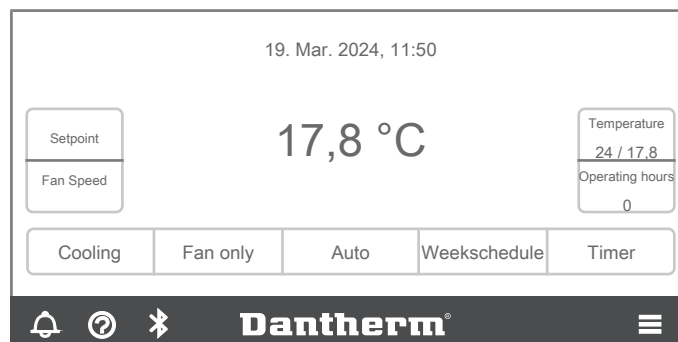

⇒ The main screen appears after 30 seconds.



2. Open the bleed screw if necessary (20) and allow air to escape from the system.
3. Retighten the bleed screw (20).

**Basic settings**

- The temperature displayed in the centre of the main screen is the actual value (ambient value). The temperature, the setpoint and the current actual value are displayed on the right side of the main screen.
- Press the  icon on the main screen to display all current and previous settings and warning messages. New messages are displayed directly next to the  icon with a yellow dot.
- Press the  icon on the main screen to display the contact data of the manufacturer, which you can use to contact the customer service.
- Some inputs must be activated by pressing the *Save* or *Back* button. When using the *Back* button, the settings are only saved if the *Save* button is not available. The display will be dimmed if it is not actuated for a certain time. This function can be deactivated in the *Preferences* menu.
- Settings that have been made but not confirmed with *Save* or *Back* are not saved.

**Setting the language, date and time**

Please proceed as follows to set the language, day and time:

1. Press the  icon on the main screen.
  - ⇒ The display changes to the following submenu.

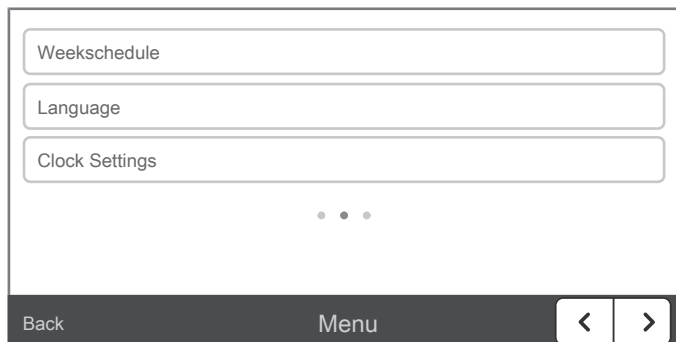

2. Press the *Language* button.
  - ⇒ The display changes to the *Language* menu.
  - ⇒ A language is already preselected.
3. Press the button for the desired language to select it.
  - ⇒ You can select the languages German, English, French, Spanish or Italian.
  - ⇒ The *Save* button appears.



4. Press the *Save* button to save the setting.

⇒ The display changes to the following submenu.

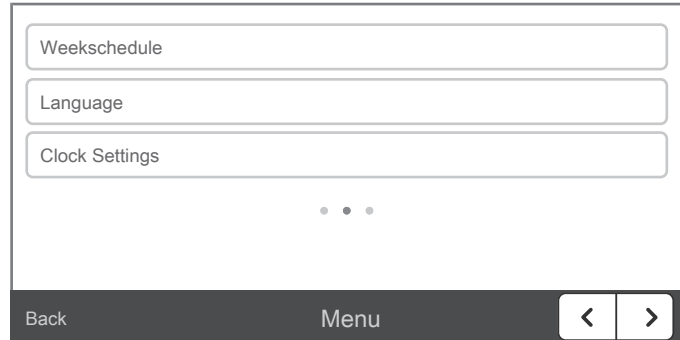

5. Press the *Clock settings* button.

⇒ The display changes to the *Clock settings* menu.

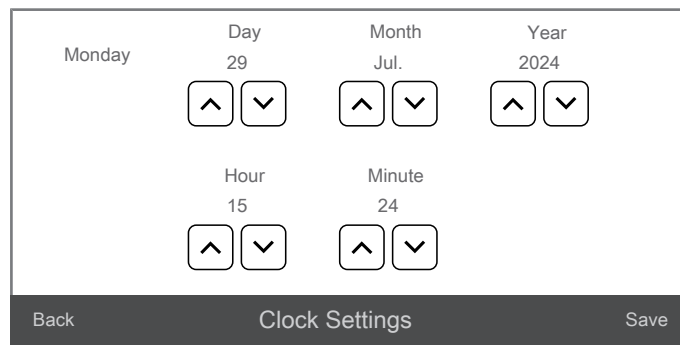

6. Press the  icon (*decrease value*) or the  icon (*increase value*) to set the day, month, year, hour and minute.

7. Press the *Save* button.

⇒ The basic settings have now been made.

8. Press the *Back* button to return to the main screen.

### Temperature setting

1. Press the *Setpoint* button.

⇒ The selected button is highlighted in grey.



2. Press the - or + button to adjust the desired temperature setpoint.

⇒ After a short time, the actual value is shown again in the centre of the display. The setpoint and actual value are still displayed on the right-hand side in the Temperature field.

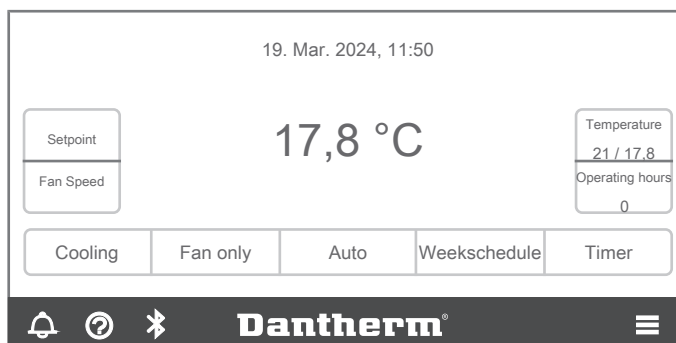

### Setting the fan speed

1. Press the *Fan Speed* button on the main screen.

⇒ The selected button is highlighted in grey.

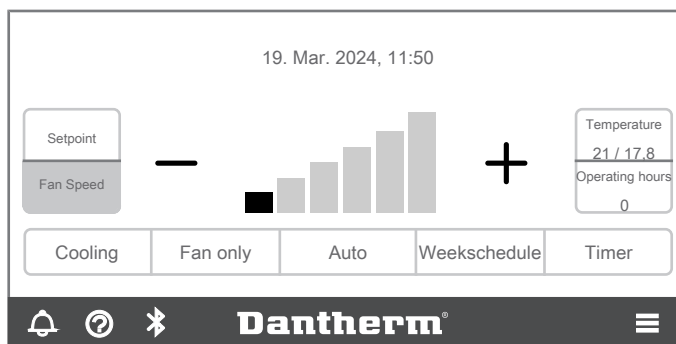

2. Press the - or + button to set the desired fan speed.

⇒ The activated fan level can be read from the black bars. One bar stands for one fan stage each.

|   |   |
|---|---|
| Speed 1 corresponds to 850 m <sup>3</sup> /h  | Speed 4 corresponds to 1150 m <sup>3</sup> /h |
| Speed 2 corresponds to 950 m <sup>3</sup> /h  | Speed 5 corresponds to 1250 m <sup>3</sup> /h |
| Speed 3 corresponds to 1050 m <sup>3</sup> /h | Speed 6 corresponds to 1450 m <sup>3</sup> /h |

### Setting the operating mode

The device comes with three different operating modes: cooling, ventilation and automatic mode.

Please proceed as follows to set the operating mode:

1. Press the *Cooling* button on the main screen.

⇒ The selected button is highlighted in grey.

⇒ The icon for *Cooling* mode appears at the top right of the display.

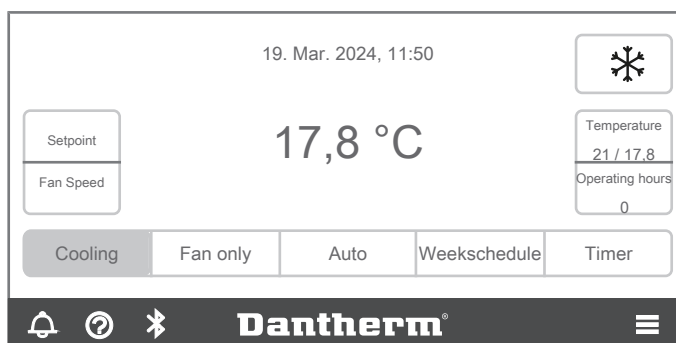

- ⇒ The air is cooled to the temperature set in the *Setpoint* field. The previously set fan speed is also activated. The device will switch to standby mode.
- 2. Press the *Fan only* button on the main screen.
  - ⇒ The selected button is highlighted in grey.
  - ⇒ The icon for *Fan only* mode appears at the top right of the display.

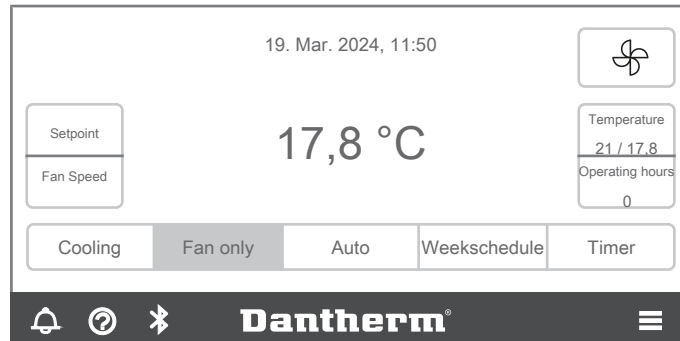

- ⇒ The air is not cooled, but circulated at the selected fan speed. The water circuit to the outdoor unit is switched off in this case.
- 3. Press the *Auto* button.

- ⇒ The selected button is highlighted in grey.
- ⇒ The icon for automatic mode only mode appears at the top right of the display.

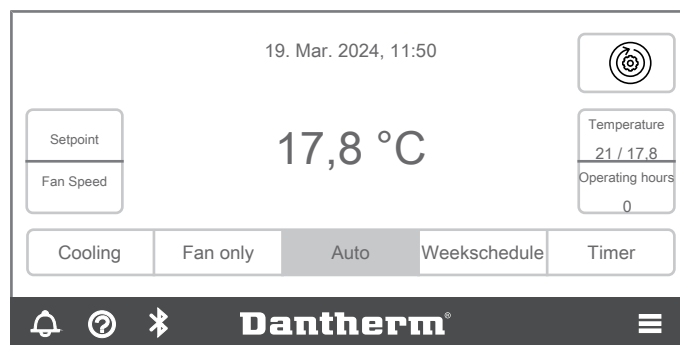

- ⇒ The air is cooled to the temperature set in the *Setpoint* field. The cooling capacity and fan performance are set automatically depending on the actual temperature.

**Setting a weekly schedule**

- 1. Press the ≡ icon on the main screen.
  - ⇒ The display changes to the following submenu.

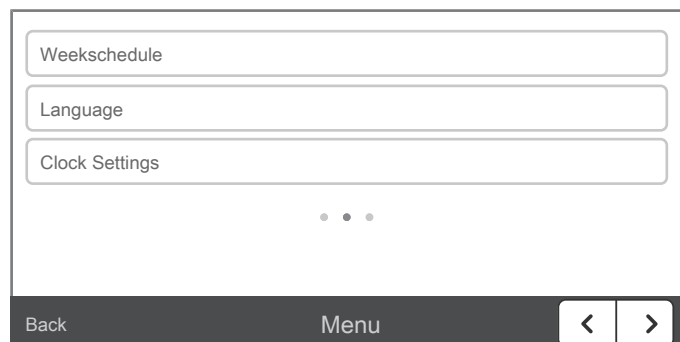

2. Press the *Weekschedule* button.

⇒ The display changes to the *Weekschedule* submenu.

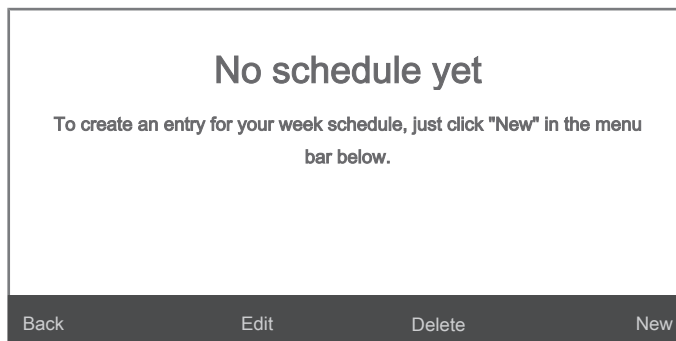

3. Press the *New* button to create a new weekly schedule.

⇒ The display changes to the *Switching Time* submenu.



4. Press the *Weekschedule* button.

⇒ The display changes to the *Day* menu.

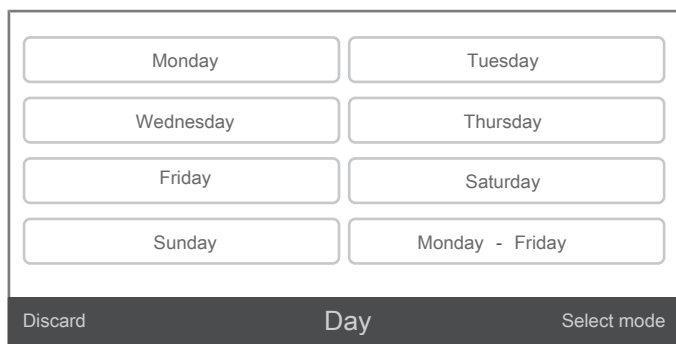

5. Press the desired day of the week to activate it.

⇒ The button is highlighted in grey.

6. Press the *Select mode* button to confirm the entry.

⇒ The display changes to the *Switching Time* menu again.



7. Press the *Fan level* button to set the desired level.

⇒ The display changes to the *Fan Level* menu.

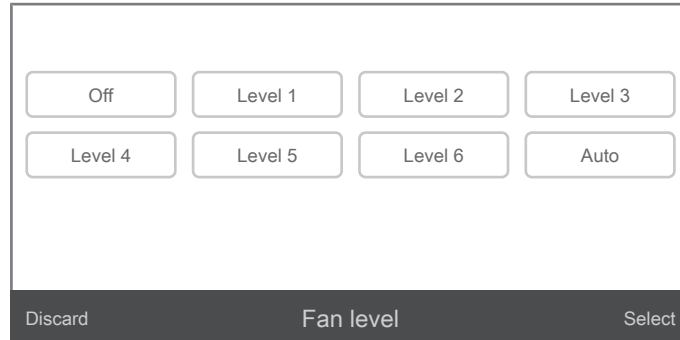

⇒ Press the *Level 1 – Level 6* button (activation of a fan level), the *Auto* button (activation of automatic mode) or the *Off* button (ventilation is deactivated).

⇒ The selected button is highlighted in grey.

8. Press the *Select* button to confirm the entry.

⇒ The display changes to the *Switching Time* menu again.



9. Press the *Setpoint* button.

⇒ The display changes to the *Setpoint* menu.

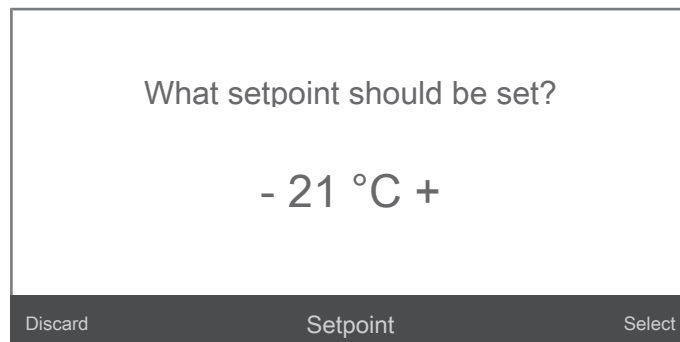

10. Press the - or + button to adjust the desired temperature setpoint.

11. Press the *Select* button to save the entry.

⇒ The display changes to the *Switching Time* menu again.

|              |         |
|--------------|---------|
| Weekschedule | Monday  |
| Fan level    | Level 1 |
| Setpoint     | 21 °C   |
| Time         | 12:00   |

Cancel      Switching Time      Save

12. Press the *Time* button.

⇒ The display changes to the *Time* menu.

At what time should this event begin?

00 h      30min

↑ ↓      ↑ ↓

Discard      Time      Select

13. Press the  icon (*decrease value*) or the  icon (*increase value*) to set the hours, minutes and seconds.

14. Press the *Select* button to confirm the entry.

⇒ Ventilation mode with the set fan speed and automatic mode start at the set time.

⇒ The display changes to the *Switching Time* menu again.

15. Press the *Save* button.

16. Press the *Back* button until you have returned to the main screen.

**Activating the locking function**

The locking function prevents the buttons on the control panel from being used. Proceed as follows to set your own PIN:

1. Press the ☰ icon on the main screen.  
⇒ The display changes to the following submenu.

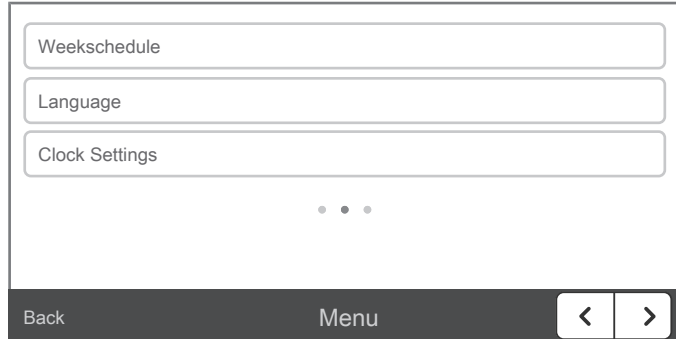

2. Press the < > icon (next/back).
3. Press the *Lock settings* button.

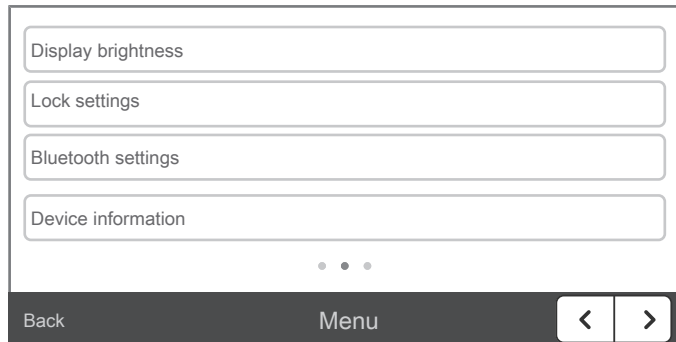

⇒ The display changes to the *Lock settings* menu.

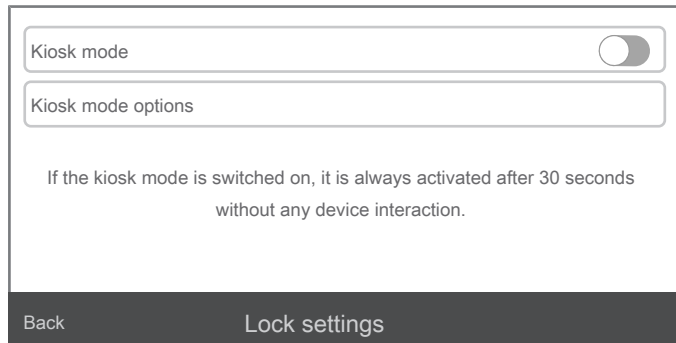

4. Press the *Kiosk mode* button.  
⇒ The display changes to the submenu for creating the PIN.
5. Then press the empty button and create a 5-digit PIN in the subsequent menu.
6. Press the *OK* button and then *OK* again.  
⇒ The screen lock is activated and the device can no longer be operated.  
⇒ The 🗑 icon appears at the bottom right of the main screen.

**Activating the locking function for certain functions**

Please proceed as follows if you want to activate the PIN for certain functions only:

1. Press the *Kiosk mode options* button on the *Lock settings* screen.  
⇒ The display for entering the PIN appears.
2. Enter your PIN.  
⇒ The display changes to the *Kiosk mode options* menu.

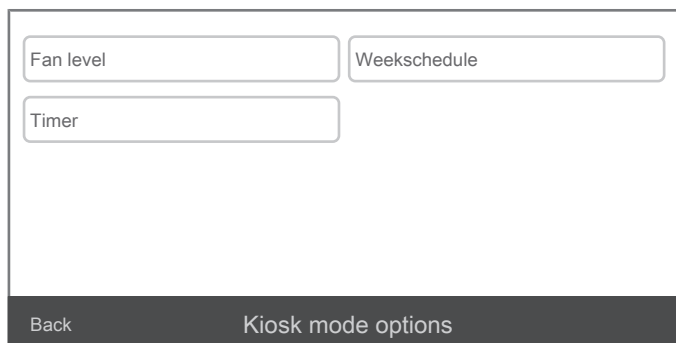

3. Press the desired button to deactivate the function or setting.  
⇒ The selected button is highlighted in grey.

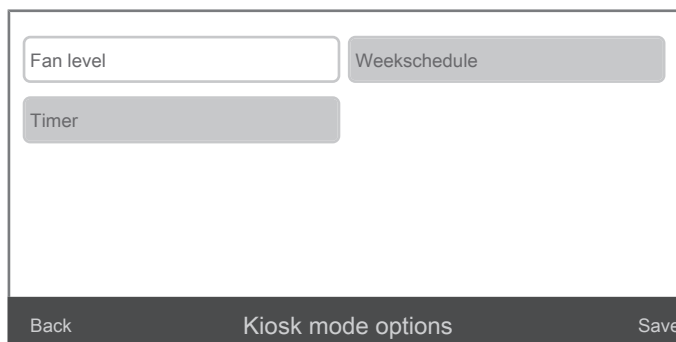

4. Press the *Save* button to activate the locking function for the selected function or setting.  
⇒ The locking function remains activated even if the device is switched off and on again.



**Info**

You can disable the locking function for a function by pressing the activated button and then pressing the *Save* button.

**Restoring the default settings after a power failure**

When the power is switched on again after a power failure, the device is in standby mode after switch-on and the default settings are used. Please proceed as follows to reactivate the settings used before the power failure:

1. Press the ☰ icon on the main screen.  
⇒ The display changes to the following submenu.

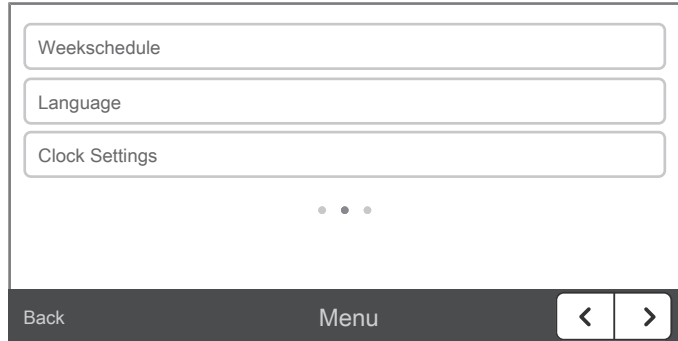

2. Press the < > icon (next) twice.

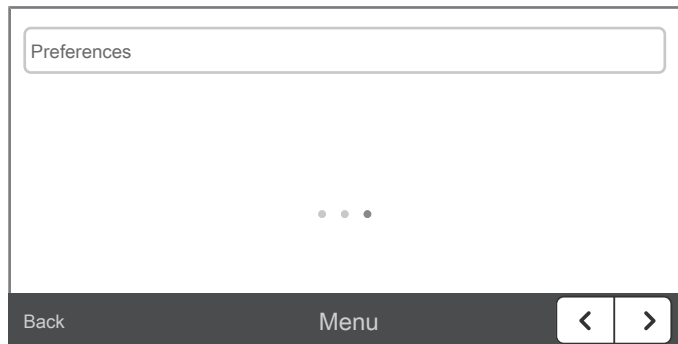

3. Press the *Preferences* button.  
⇒ The display changes to the *Preferences* menu.

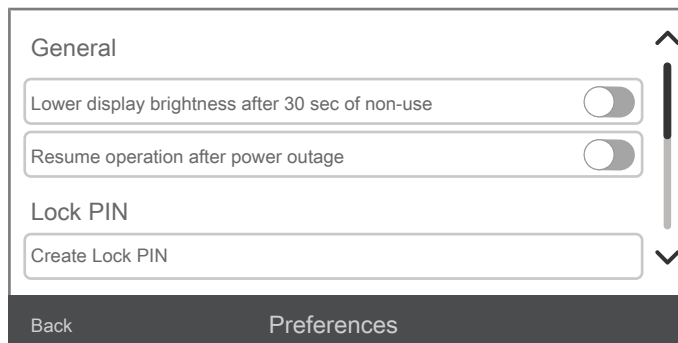

4. Press the *Resume operation after power outage* button.

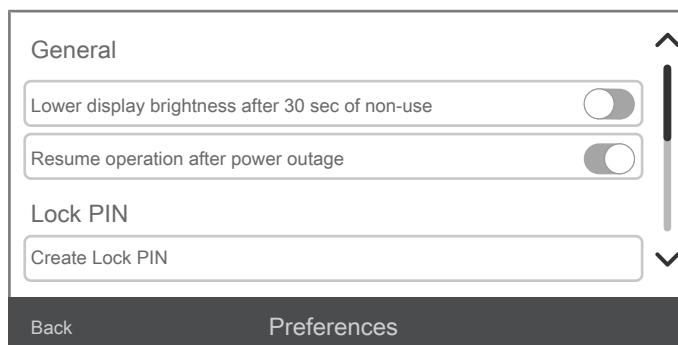

5. Press the *Back* button until you have returned to the main screen.

**Automatic defrosting**

At low ambient temperatures, ice may form at the vaporizer during air conditioning. The device will perform automatic defrosting. The ❄️ icon is shown at the top right of the control panel display (1) and the *Cooling* button is highlighted in grey. The device is now in defrosting mode. Here, hot refrigerant is led into the iced vaporizer for the surfaces to defrost. Automatic defrosting cannot be activated or deactivated manually.

The duration of defrosting can vary. The automatic defrost system integrated in the device automatically switches on the defrost cycle at regular intervals.

Do not switch off the device during automatic defrosting. Do not remove the mains plug from the mains socket.

After automatic defrosting the device keeps running for approx. 90 seconds for the purpose of air circulation – regardless of the ambient temperature and the desired room temperature. Afterwards the device resumes operation with the set values.

**Notice**

Do not scrape off any ice. At low room temperatures, usually below 15 °C, ice can form inside the basic device, for example on the vaporizer, which is located behind the air filter. In this case, also wait for the automatic defrosting process to be completed. If defrosting could not be completed (residual ice formation), please contact customer service.

**Shutdown**



**Warning of electrical voltage**

Do not touch the mains plug with wet or damp hands.

- Remove the condensate from the basic device. To do so, set a setpoint for the temperature that is higher than the actual room temperature (see Operation chapter) and allow the device to run for 3 minutes with this setting. The condensate is channelled to the outdoor unit and evaporates.
- Switch off the device by setting the main switch (4) to position **0**.
- Disconnect the device from the mains by removing the mains plug from the socket. When doing so, be sure to hold the plug, not the cable.
- Clean the device according to the Maintenance chapter.
- Store the device according to the Transport and storage chapter.

**Available accessories**

| Designation          | Article number |
|----------------------|----------------|
| Hose set Standard    | 1.210.000.135  |
| Hose set Heavy Duty  | 1.210.000.136  |
| AC 7000 outdoor unit | 1.210.001.093  |

## Errors and faults

The device has been checked for proper functioning several times during production. If malfunctions occur nonetheless, check the device according to the following list.



### Wear safety glasses

For start-up, maintenance and troubleshooting always wear suitable safety glasses.



### Wear protective gloves

For start-up, maintenance and troubleshooting always wear suitable protective gloves.

#### The device does not start:

- Check the power connection.
- Check the power cable and mains plug for damage. If you notice damages, do not try to take the device back into operation. If the supply cord is damaged, it must be replaced by the manufacturer, its service agent or similarly qualified persons in order to avoid a hazard.
- Check the on-site fusing.
- Observe the operating temperature according to the chapter Technical annex.
- If the device is not starting, have the electricians checked by a specialist company or by the manufacturer.
- After switch-off, allow the device to cool down for a few minutes before switching it back on.

#### The device works with reduced or no cooling capacity:

- Check whether *Cooling* mode or automatic mode is selected.
- Check the air filter for dirt. If necessary, clean or replace the air filter.
- Check the minimum distance to walls or other objects. Position the device a little more in the room's centre if required.
- Check the temperature setting at the device. Reduce the set temperature if it is higher than the room temperature.

#### The device is loud or vibrates:

- Check whether the device is set up in a stable and upright position.

#### Condensate is leaking from the basic device:

- Check the device for leaks.

#### The compressor does not start:

- Check whether the overheating protection of the compressor has tripped. Disconnect the device from the mains and let it cool down for approx. 10 minutes before reconnecting it.
- The compressor may start up with a delay of 3 minutes, as it is provided with an internal protection against direct restart.

**The device gets very warm, is loud or is losing power:**

- Check the air inlet and air filter for dirt. Remove external dirt.
- From the outside, check the device for dirt (see chapter Maintenance). If the inside of the device is dirty, have it cleaned by a specialist company for cooling and air-conditioning or by the manufacturer.

**The device still does not operate correctly after these checks:**

- Please contact the customer service. If necessary, bring the device to a specialist company for cooling and air-conditioning or to the manufacturer for repair.

# Maintenance

## Maintenance intervals

| Maintenance and care interval   | before every start-up | as needed | at least every 2 weeks | at least every 4 weeks | at least every 6 months | at least annually |
|---|-----------------------|-----------|------------------------|------------------------|-------------------------|-------------------|
| Check air inlet and outlet for dirt and foreign objects and clean if necessary      | X                     |           |                        | X                      |                         |                   |
| Clean the exterior  |                       | X         |                        |                        |                         | X                 |
| Visually check the inside of the device for dirt                                    |                       | X         |                        |                        |                         | X                 |
| Check the air filter for dirt and foreign objects and clean or replace if necessary | X                     |           | X                      |                        |                         |                   |
| Replace the air filter  |                       |           |                        |                        | X                       |                   |
| Check for damage  | X                     |           |                        |                        |                         |                   |
| Check the attachment screws   |                       | X         |                        |                        |                         | X                 |
| Test run  |                       |           |                        |                        |                         | X                 |

## Maintenance and care log

Device type: .....

Device number: .....

| Maintenance and care interval   | 1 | 2 | 3 | 4 | 5 | 6 | 7 | 8 | 9 | 10 | 11 | 12 | 13 | 14 | 15 | 16 |
|---|---|---|---|---|---|---|---|---|---|----|----|----|----|----|----|----|
| Check air inlets and outlets for dirt and foreign objects and clean if necessary    |   |   |   |   |   |   |   |   |   |    |    |    |    |    |    |    |
| Check the air filter for dirt and foreign objects and clean or replace if necessary |   |   |   |   |   |   |   |   |   |    |    |    |    |    |    |    |
| Clean the exterior  |   |   |   |   |   |   |   |   |   |    |    |    |    |    |    |    |
| Visually check the inside of the device for dirt                                    |   |   |   |   |   |   |   |   |   |    |    |    |    |    |    |    |
| Replace the air filter  |   |   |   |   |   |   |   |   |   |    |    |    |    |    |    |    |
| Check the attachment screws   |   |   |   |   |   |   |   |   |   |    |    |    |    |    |    |    |
| Test run  |   |   |   |   |   |   |   |   |   |    |    |    |    |    |    |    |

|                         |                         |                         |                         |
|-------------------------|-------------------------|-------------------------|-------------------------|
| 1. Date:<br>Signature:  | 2. Date:<br>Signature:  | 3. Date:<br>Signature:  | 4. Date:<br>Signature:  |
| 5. Date:<br>Signature:  | 6. Date:<br>Signature:  | 7. Date:<br>Signature:  | 8. Date:<br>Signature:  |
| 9. Date:<br>Signature:  | 10. Date:<br>Signature: | 11. Date:<br>Signature: | 12. Date:<br>Signature: |
| 13. Date:<br>Signature: | 14. Date:<br>Signature: | 15. Date:<br>Signature: | 16. Date:<br>Signature: |

## Safety instructions for maintenance



### **Wear safety glasses**

For start-up, maintenance and troubleshooting always wear suitable safety glasses.



### **Wear a protective mask**

For cleaning and maintenance tasks wear an appropriate protective mask.



### **Wear protective gloves**

For start-up, maintenance and troubleshooting always wear suitable protective gloves.



### **⚠ Warning of electrical voltage**

Do not touch the mains plug with wet or damp hands.

- Switch the device off.
- Disconnect the device from the mains by removing the mains plug from the socket. When doing so, be sure to hold the plug, not the cable.



### **⚠ Warning of electrical voltage**

Tasks which require the device to be opened must only be carried out by authorised specialist companies or by the manufacturer.



### **⚠ Danger**

#### **Refrigerant R454C!**

H221 – Flammable gas.

H280 – Contains gas under pressure; may explode if heated.

P210 – Keep away from heat, sparks, open flames and other ignition sources. No smoking.

P377 – Leaking gas fire; Do not extinguish, unless leak can be stopped safely.

P381 – Eliminate all ignition sources if safe to do so.

P410 and P403 – Protect from sunlight. Store in a well-ventilated place.

- The entire refrigerant circuit is a maintenance-free, hermetically sealed system and may only be maintained or repaired by specialist companies for cooling and air-conditioning or by the manufacturer.

## Safety signs and labels on the device

Check the safety signs and labels attached to the device at regular intervals. Replace illegible safety signs!

## Cleaning the housing

Clean the housing with a soft, damp and lint-free cloth. Make sure that no moisture enters the housing. Protect electrical components from moisture. Do not use any aggressive cleaning agents such as cleaning sprays, solvents, alcohol-based or abrasive cleaners to dampen the cloth.

## Visual inspection of the inside of the device for dirt

1. Remove the air filter.
2. Use a torch to illuminate the openings of the device.
3. Check the inside of the device for dirt.
4. If you see a thick layer of dust, have the inside of the device cleaned by a specialist company for cooling and air-conditioning or by the manufacturer.
5. Put the air filter back in.

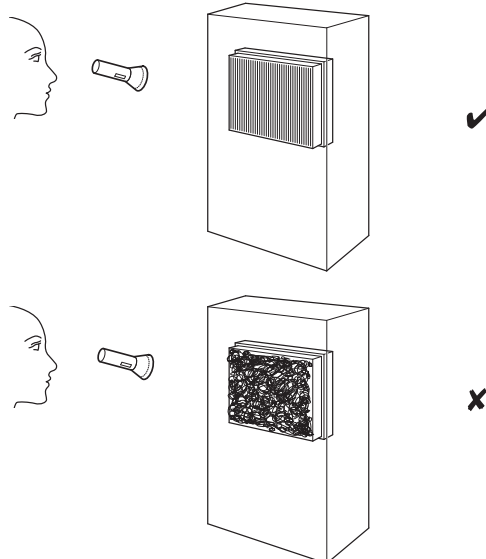

## Cleaning the air filter



### **Warning**

Make sure that the air filter is not worn or damaged. The corners and edges of the air filter must not be deformed or rounded. Before reinserting the air filter, make sure that it is undamaged and dry!

1. Loosen the two screws (22) at the top left and right of the ventilation plate at the air inlet (5).
2. Remove the ventilation plate at the air inlet (5) from the device.

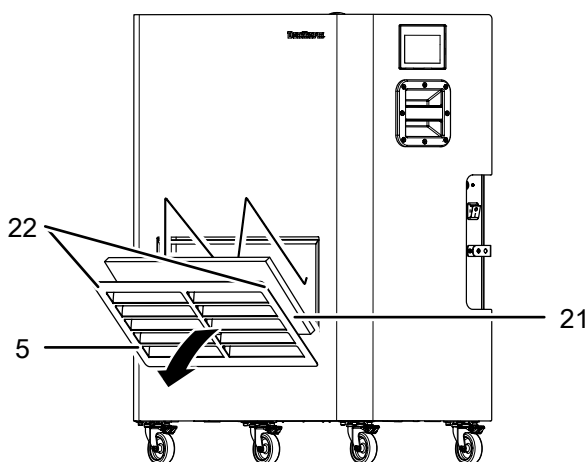

3. Remove the air filter from the filter insert.
4. Dispose of the air filter (21) according to the national regulations.
5. Insert a new air filter into the filter insert.
6. Insert the new air filter with the filter insert (21) into the device.
7. Refit the ventilation plate at the air inlet (5) and fasten the ventilation plate using the two screws (22) at the top left and right.

## Venting the outdoor unit

After a longer period of non-use, the outdoor unit must be vented.

Please proceed as follows:

- ✓ The device is switched on (see Start-up and Operation chapters).
1. Loosen the bleed screw (20).
  2. Release the entire air from the system.
  3. Retighten the bleed screw (20).

## Checking and topping up the water / glycol mixture



### **Danger**

#### **Risk of injury from contact with glycol!**

Contact with the escaping water / glycol mixture can cause severe eye irritation and internal injuries when swallowed (e.g. kidney damage).

Avoid contact with the water / glycol mixture.

Never drink the water / glycol mixture!

Always wear safety glasses, protective gloves and tight-fitting work clothing.

In case of contact with eyes: Rinse carefully with water for some minutes. Remove contact lenses, if applicable. Continue rinsing.

Remove any escaping liquid.

Observe the relevant safety data sheets.



### **Warning**

There is a risk of injury if the liquid heats up and vaporises! Never remove the lid of the tank when the device is switched on or when the liquid in the tank has heated up.

Always wear a protective mask, protective gloves and protective glasses when filling!

### **Notice**

The water / glycol circuit is filled with a fluid consisting of 35 % Long Life IAT (Inorganic Acid Technology) ethylene glycol (ethanediol 3,5,5-trimethylhexanoate) and 65 % water. The mixing ratio of 35 % ethanediol 3,5,5-trimethylhexanoate to 65 % water must not be changed when adding additional liquid!

Proceed as follows to fill the water / glycol circuit with liquid:

- ✓ The device is switched off and the plug is disconnected from the mains socket.
  - ✓ The contained water / glycol mixture has cooled down.
1. Check whether the outdoor unit is lower or at most the same height as the basic device. If this is the case, continue with step 3.
  2. Disconnect the outdoor unit from the basic device, place both units on one level and connect them with the hose set (see chapter "Assembly and start-up").
  3. Remove the screw cap from the tank (9).
  4. Check the glycol content with an antifreeze tester according to the technical data. The mixing ratio must be 35 % Long Life IAT (Inorganic Acid Technology) ethylene glycol (ethanediol 3,5,5-trimethylhexanoate) and 65 % water.
  5. Top up the water / glycol mixture with the correct mixing ratio until the filling level is 40 mm below the top edge of the tank.
  6. Place the screw cap back on the tank (9) and tighten it.
  7. Plug the mains plug into the mains socket. Switch on the basic device and activate the cooling mode. Set a setpoint that is lower than the current room temperature (see Operation chapter).
  8. The device is fitted with an automatic venting system that collects any remaining air inside the system and channels it into the tank. A gurgling sound is caused during this process. Allow the device to run until you can no longer hear any gurgling sounds.
  9. Switch the basic device off and remove the mains plug from the mains socket.

10. Check the liquid level in the tank.
  - ⇒ If the filling level is a maximum of 40 mm below the top edge of the tank, the system is filled correctly, otherwise repeat the steps from step 3 onwards.
11. If the basic device or outdoor unit have been moved for filling, disconnect the units and return them to their original installation location. Reconnect the units with the hose set (see chapter "Assembly and start-up").

### Notice

When refilling an empty basic device for the first time, venting the system can be accelerated if you open the bleed screw (20) on the outdoor unit during the filling process (see "Venting the outdoor unit").

## Activities required after maintenance

If you want to continue using the device:

- If the basic device has been moved, allow it to stand for 30 minutes before using it again so that the lubricating oil can be returned to the compressor. Acting contrary might lead to compressor damage and a malfunctioning basic device.
- Reconnect the device to the mains.

If you do not intend to use the device for a considerable time:

- Store the device according to the Transport and storage chapter.

## Technical annex

### Technical data

| Model  | AC 7000   |
|--|---|
| Article number   |   |
| AC 7000 complete unit  | 1.003.000001  |
| basic device   | 1.210.001090  |
| outdoor unit   | 1.210.001093  |
| standard hose set  | 1.210.000135  |
| Cooling capacity (at 25 °C)  | 6.5 kW  |
|  | 22,178 BTU/h  |
| Max. cooling capacity  | 7 kW  |
|  | 23,884 BTU/h  |
| Operating range  |   |
| outdoor unit   | -5 °C to 45 °C  |
| basic device   | 5 °C to 43 °C   |
| Max. air volume flow   | 1450 m <sup>3</sup> /h                                    |
| Min. air volume flow   | 800 m <sup>3</sup> /h                                     |
| Fusing  | 13 A  |
| Power supply   | 230 V / 50 Hz   |
| WLAN transmission frequency  | 2.4 GHz   |
| Maximum transmission capacity  | < 20 dBm  |
| Type of protection   |   |
| outdoor unit   | IP X4   |
| basic device   | IP X2   |
| Max. power input (cooling operation)   | 2.95 kW   |
| Sound pressure level at a distance of 1 m  | 62 dB(A)  |
| Heat transfer fluid in the second cooling circuit (with a hose set (10 m))               | 9.75 l water / 5.25 l glycol                              |
| Glycol specification   | Long Life IAT (Inorganic Acid Technology) ethylene glycol |
| Refrigerant (basic device)   | R454C   |
| Amount of refrigerant  | 840 g   |
| GWP factor   | 148   |
| CO <sub>2</sub> equivalent   | 0.124 t   |
| Suction side pressure  | 1 MPa   |
| Discharge side pressure  | 2.5 MPa   |
| Max. permissible pressure  | 2.8 MPa   |
| Dimensions of the basic device (length x width x height)                                 | 400 x 880 x 1030 mm                                       |
| Dimensions of the outdoor unit (length x width x height)                                 | 250 x 700 x 580 mm  |
| Minimum distance to walls and other objects (basic device):                              |   |
|  | A (top): 30 cm  |
|  | B (rear): 30 cm   |
|  | C (side): 30 cm   |
|  | D (front): 30 cm  |

| Model   | AC 7000   |
|---|---|
| Minimum distance to walls and other objects (outdoor unit): | A (top): 30 cm<br>B (rear): 30 cm<br>C (side): 300 cm<br>D (front): 30 cm |
| Weight basic device   | 108 kg  |
| Weight outdoor unit   | 21 kg   |
| Weight standard hose set                                    | 14 kg   |

Circuit diagrams

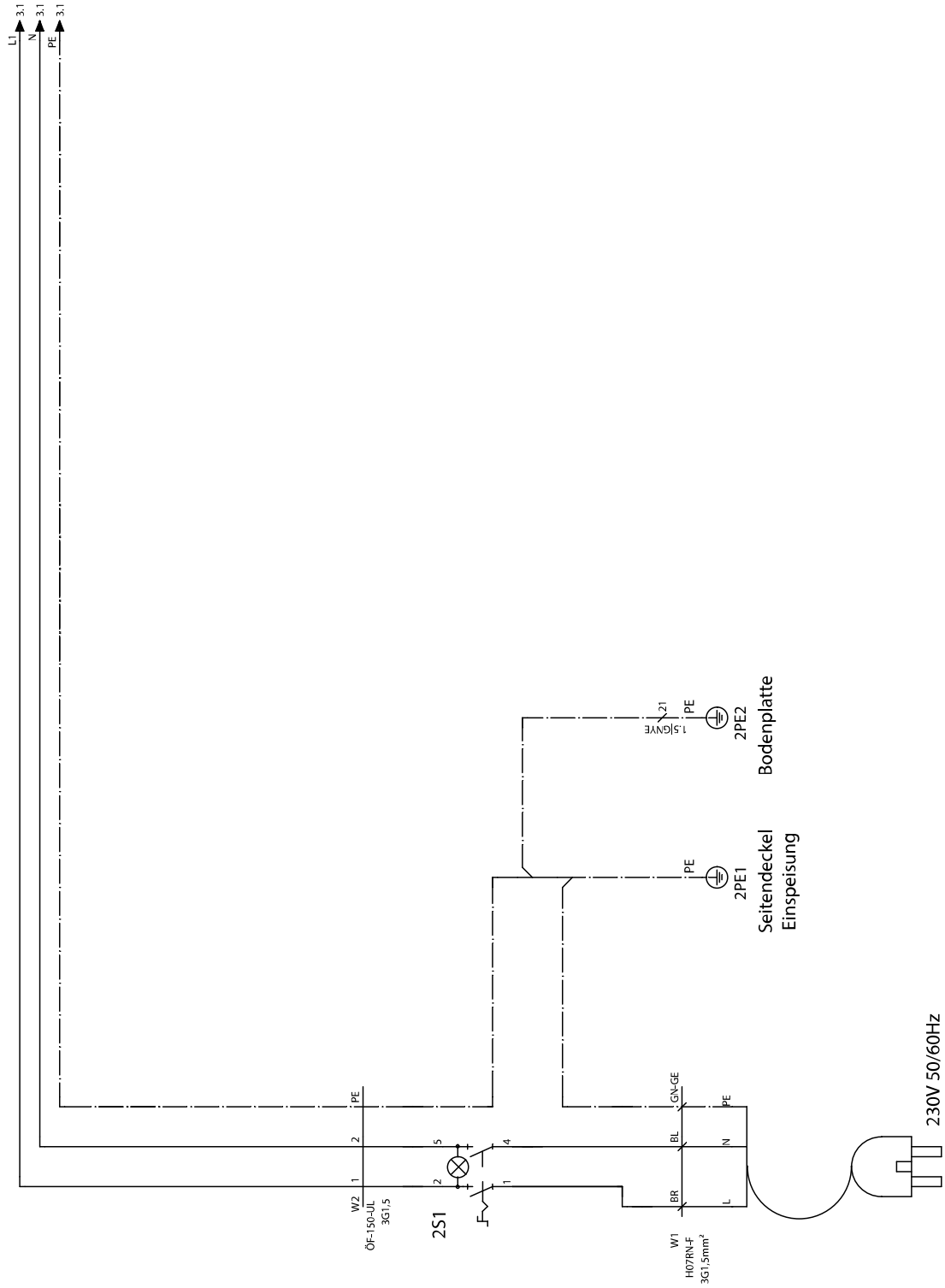

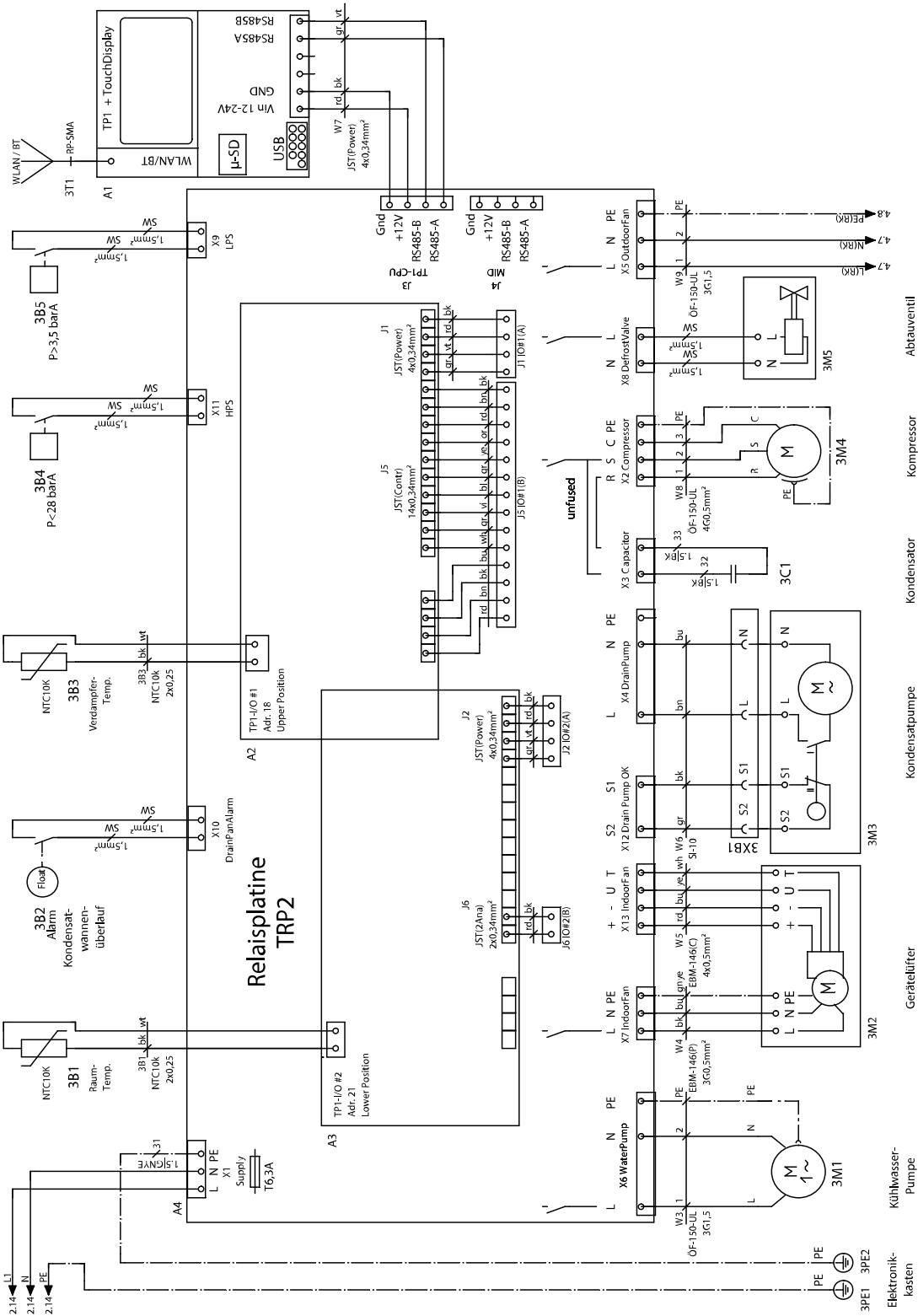

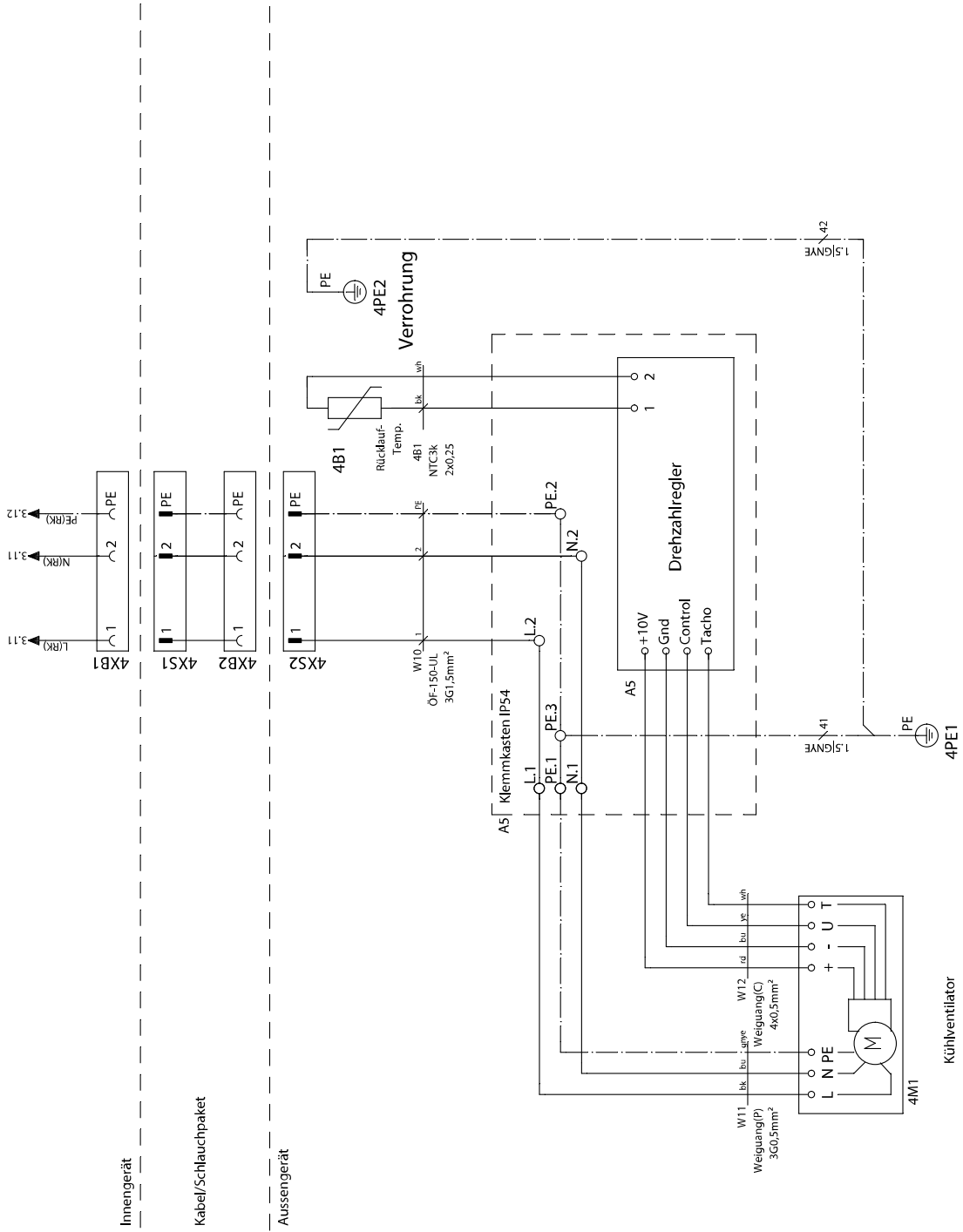

**Overview and list  
of spare parts  
basic device**

**Note:** The position numbers of the spare parts differ from those describing the positions of other parts mentioned in this operating manual.

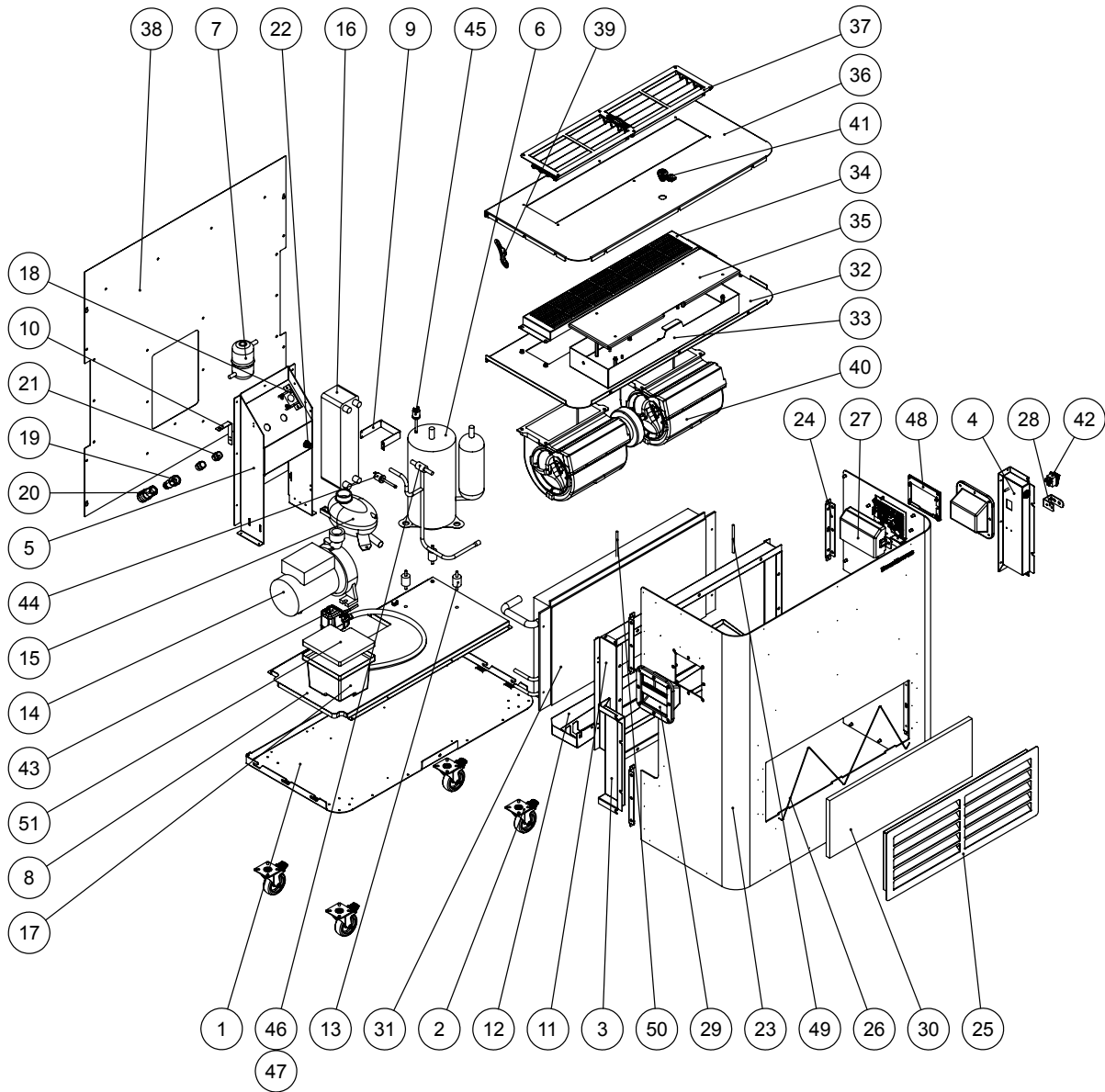

| No. | Quantity | Designation             | Article number                           |
|-----|----------|-------------------------|--|
| 1   | 1        | Bottom                  | P10008704                                |
| 2   | 4        | Wheel                   | P10001530                                |
| 3   | 1        | Side panel              | P10008710                                |
| 4   | 1        | Side panel              | P10008827                                |
| 5   | 1        | Connection plate        | P10008705                                |
| 6   | 1        | Defrost solenoid valve  | on request                               |
| 7   | 1        | Receiver                | P10008755                                |
| 8   | 1        | Bottom panel            | P10008706                                |
| 9   | 1        | Bracket                 | P10008707                                |
| 10  | 1        | Receiver holder         | P10008786                                |
| 11  | 1        | Retaining plate         | P10008743                                |
| 12  | 1        | Condensate drain        | P10008723                                |
| 13  | 3        | Rubber buffer           | P10008783                                |
| 14  | 1        | Pump                    | on request                               |
| 15  | 1        | Compensation tank       | P10008754                                |
| 16  | 1        | Heat exchanger          | P10008400                                |
| 17  | 1        | Condensation tray       | P10008756                                |
| 18  | 1        | Pipe clamp              | P10008217                                |
| 19  | 1        | Quick coupling          | P10008773                                |
| 20  | 1        | Quick coupling          | P10008772                                |
| 21  | 2        | Double threaded nipple  | P10008829                                |
| 22  | 1        | Bulkhead connector      | T10004014                                |
| 23  | 1        | Outer wall              | P10008709                                |
| 24  | 11       | Angle sheet             | P10008742                                |
| 25  | 1        | Air grille              | P10008711                                |
| 26  | 1        | Filter retainer AC 7000 | P10008845                                |
| 27  | 1        | Cover TP1               | P10008879                                |
| 28  | 1        | Cable holder            | P10008791                                |
| 29  | 2        | Handle                  | P10008843                                |
| 30  | 1        | Filter                  | P10008846                                |
| 31  | 1        | Vaporizer               | P10008758                                |
| 32  | 1        | Intermediate plate      | P10008712                                |
| 33  | 1        | Electrical box          | internal components available on request |
| 34  | 1        | Finger protection       | P10008792                                |
| 35  | 1        | Cover                   | P10008851                                |
| 36  | 1        | Air outlet              | P10008714                                |
| 37  | 1        | Air outlet frame        | on request                               |
| 38  | 1        | Rear wall               | P10008722                                |
| 39  | 1        | Air outlet holder       | P10008771                                |
| 40  | 1        | Fan                     | on request                               |
| 41  | 1        | Lock                    | P10008826                                |
| 42  | 1        | Rocker switch           | on request                               |
| 43  | 1        | Condensate pump         | P10008729                                |
| 44  | 1        | High-pressure switch    | on request                               |
| 45  | 1        | Low pressure switch     | on request                               |
| 46  | 1        | Defroster               | on request                               |
| 47  | 1        | Magnet valve            | on request                               |
| 48  | 1        | Display frame, embedded | P10008757                                |

| No. | Quantity | Designation            | Article number |
|-----|----------|------------------------|----------------|
| 49  | 1        | Air temperature sensor | P10008734      |
| 50  | 1        | Sensor defroster       | P10008734      |
| 51  | 1        | Filter                 | P10009131      |

**Overview and list of spare parts display unit**

**Note:** The position numbers of the spare parts differ from those describing the positions of other parts mentioned in this operating manual.

**Note:** The buffer battery may only be replaced by a qualified electrician. Contact the relevant personnel or the manufacturer in this case.

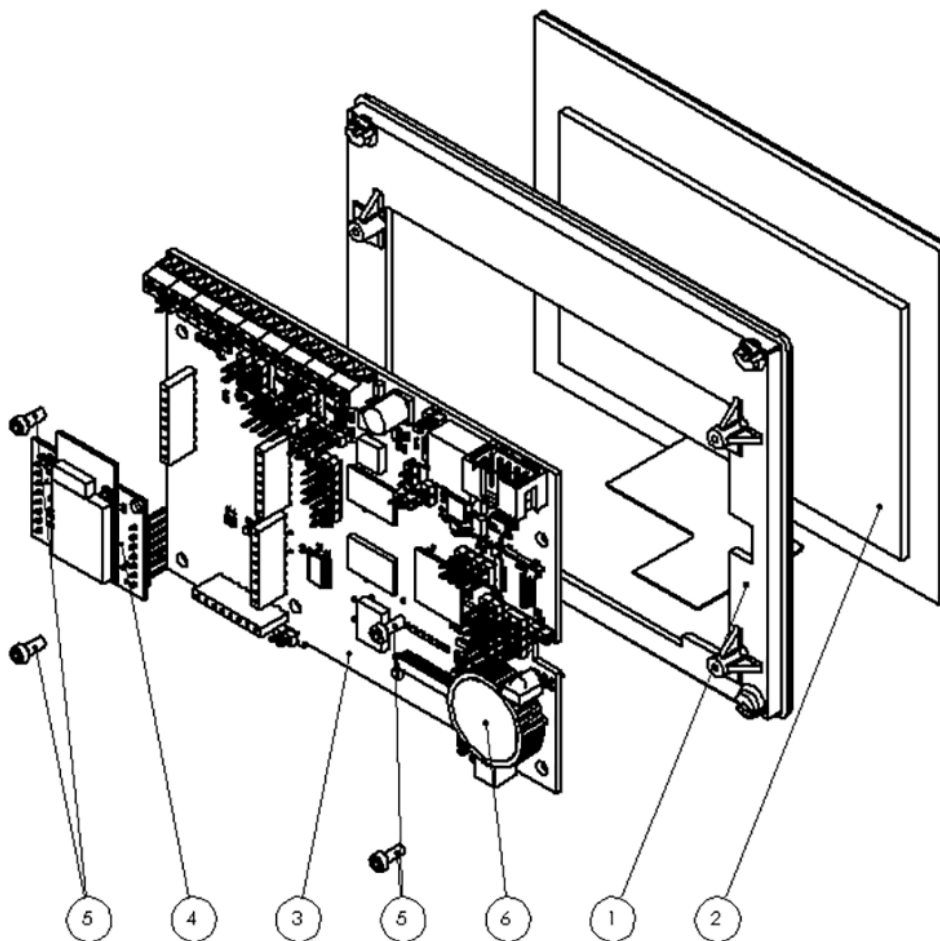

| No. | Quantity | Designation  | Article number |
|-----|----------|--|----------------|
| 1   | 1        | Display frame, embedded (T0007716)                 | P10008757      |
| 2   | 1        | Display (TFT DVT-043T-JT-R9T-P7)                   | P10007764      |
| 3   | 1        | Printed circuit board (e-mainboard)                | P10002358      |
| 4   | 1        | Printed circuit board (radio module PCB ESP32-Mod) | P10007825      |
| 5   | 4        | Screw (Liko Torx Plasfast 2.5x6 galvanised)        | P10007290      |
| 6   | 1        | Battery (CR2032)                                   | -              |

**Overview and list of spare parts outdoor unit**

**Note:** The position numbers of the spare parts differ from those describing the positions of other parts mentioned in this operating manual.

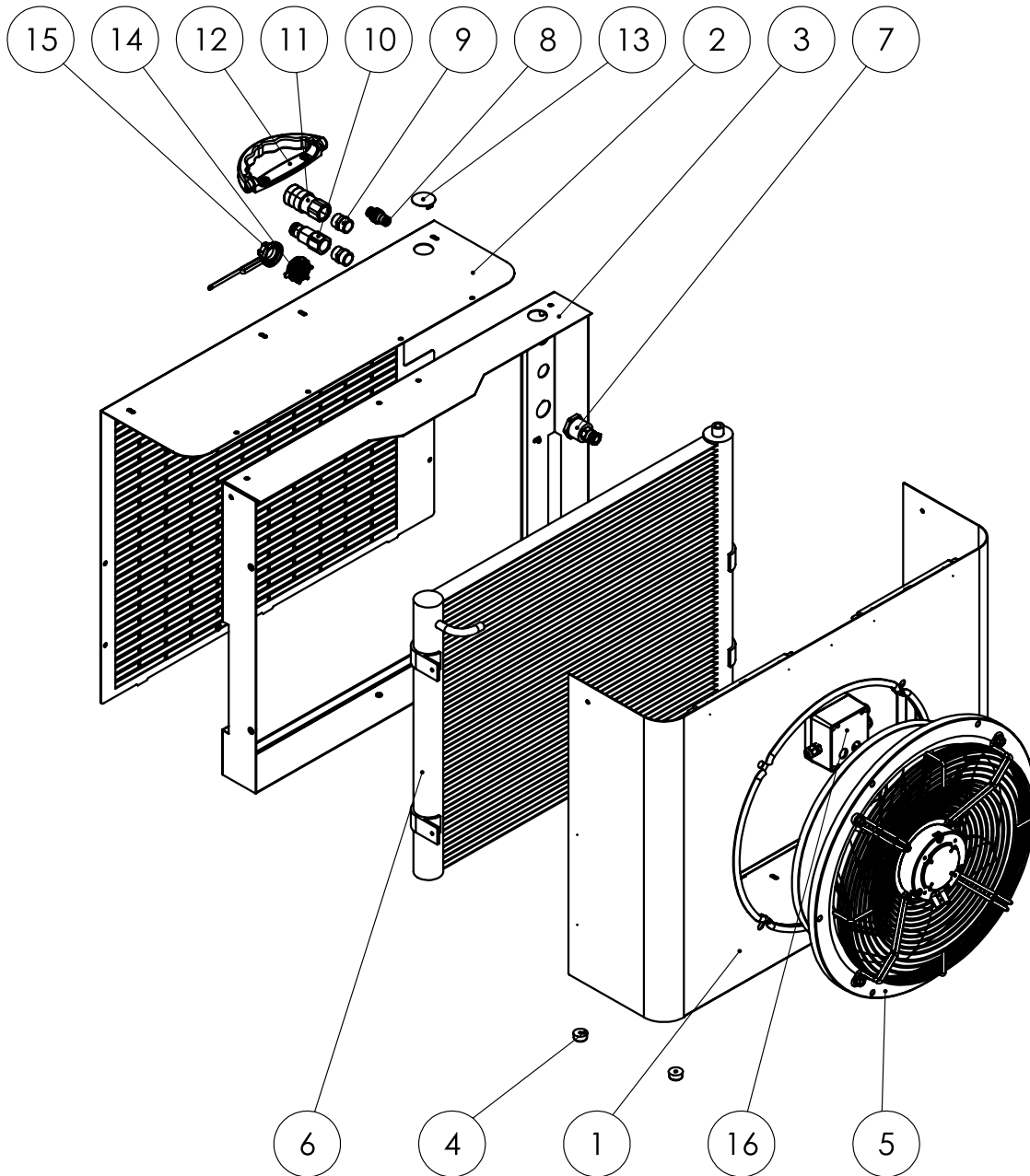

| No. | Quantity | Designation            | Article number |
|-----|----------|------------------------|----------------|
| 1   | 1        | Outer wall             | P10008725      |
| 2   | 1        | Rear wall              | P10008726      |
| 3   | 1        | Partition wall         | P10008727      |
| 4   | 4        | Rubber buffer          | P10000501      |
| 5   | 1        | Fan                    | P10008740      |
| 6   | 1        | Radiator               | P10008759      |
| 7   | 1        | Screw cap              | P10008788      |
| 8   | 2        | Bulkhead connector     | T10004014      |
| 9   | 4        | Double threaded nipple | P10008829      |
| 10  | 2        | Quick coupling         | P10008773      |
| 11  | 2        | Quick coupling         | P10008772      |
| 12  | 1        | Handle                 | P10001246      |
| 13  | 1        | Hole plug              | P10001676      |
| 14  | 1        | Built-in connector     | P10008673      |
| 15  | 1        | Cap                    | P10000511      |
| 16  | 1        | Electric control box   | on request     |

## Disposal

Always dispose of packing materials in an environmentally friendly manner and in accordance with the applicable local disposal regulations.



The icon with the crossed-out wheeled bin indicates that this device and any associated components must not be disposed of with household waste at the end of their life, in accordance with the Waste Electrical and Electronic Equipment Directive (2012/19/EU) and national laws.

You will find collection points for free return of waste electrical and electronic equipment in your vicinity. The addresses can be obtained from your municipality or local administration. Otherwise, please contact an official recycling centre for electronic and electrical equipment authorised for your country.

The separate collection of waste electrical and electronic equipment aims to enable the re-use, recycling and other forms of recovery of waste equipment as well as to prevent negative effects for the environment and human health caused by the disposal of hazardous substances potentially contained in the equipment.

The device is operated with fluorinated greenhouse gas, which can be dangerous for the environment and contribute to global warming when emitted to the atmosphere.

Further information is provided on the nameplate.

Dispose of the refrigerant appropriately and according to the national regulations.

Dispose of the water / glycol mixture in the device properly according to the national regulations.

### Only for United Kingdom

According to Waste Electrical and Electronic Equipment Regulations 2013 (SI 2013/3113) (as amended) devices that are no longer usable must be collected separately and disposed of in an environmentally friendly manner.

| <b>ORIGINAL EU Declaration of Conformity for a machine</b><br>in accordance with 2006/42/EC, Annex II, Part 1, Section A |  |   |
|--|--|---|
| 1.   | Machine:   | Air-conditioning unit (monobloc system with heat exchanger)   |
| 2.   | Manufacturer:  | Trotec GmbH<br>Grebbener Str. 7<br>52525 Heinsberg<br>Germany<br><a href="mailto:online@trotec.com">online@trotec.com</a><br><a href="http://www.trotec.com">www.trotec.com</a> |
| 3.   | ./.  |   |
| 4.   | This declaration of conformity is issued under the sole responsibility of the manufacturer.  |   |
| 5.   | Object of the declaration:   | AC 7000<br>Year of manufacture as of: 2024  |
| 6.   | The object of the declaration described in point 5 is in conformity with the following Union harmonisation legislation:  | <ul style="list-style-type: none"> <li>• 2006/42/EC</li> <li>• 2011/65/EU</li> <li>• 2014/53/EU</li> </ul>  |
| 7.   | Applied harmonised standards: <ul style="list-style-type: none"> <li>• EN ISO 12100:2010 (Official Journal C 110 – 08/04/2011)</li> <li>• EN IEC 63000:2018 (Official Journal L 155 – 18/05/2020)</li> <li>• EN ISO 13857:2019 (Official Journal L 72 – 03/03/2021)</li> <li>• EN 60335-1:2012, EN 60335-1:2012/AC:2014, EN 60335-1:2012/A11:2014, EN 60335-1:2012/A13:2017, EN 60335-1:2012/A15:2021 (Official Journal L 115 – 13/04/2022)</li> <li>• EN 60335-2-40:2003, EN 60335-2-40:2003/A11:2004, EN 60335-2-40:2003/A12:2005, EN 60335-2-40:2003/A1:2006, EN 60335-2-40:2003/A13:2012/AC:2013, EN 60335-2-40:2003/A13:2012, EN 60335-2-40:2003/A2:2009, EN 60335-2-40:2003/AC:2006, EN 60335-2-40:2003/AC:2010 (Official Journal C 348 – 28/11/2013)</li> <li>• EN 300 328 V2.2.2 (Official Journal L 34 – 06/02/2020)</li> </ul> |   |
|  | Common specifications applied: ./.   |   |
|  | Other applied standards and specifications: ./.  |   |
| 8.   | ./.  |   |
| 9.   | The machine is subject to the conformity assessment procedure on the basis of an internal production control.  |   |
| 10.  | Other information:   | Authorised representative compiling the technical documentation:<br>Trotec GmbH<br>Grebbener Str. 7<br>52525 Heinsberg<br>Germany   |

Heinsberg, 11 June 2024



Joachim Ludwig (Managing Director)





**Dantherm Group**

Grebener Straße 7

52525 Heinsberg

Germany

☎ +49 2452 962-0

✉ [online@trotec.com](mailto:online@trotec.com)

[www.trotec.com](http://www.trotec.com)

---

Dantherm can accept no responsibility for possible errors and changes (en)

Der tages forbehold for trykfejl og ændringer (da)

Irrtümer und Änderungen vorbehalten (de)

Dantherm n'assume aucune responsabilité pour erreurs et modifications éventuelles (fr)

---

